



# **SPECIFICATIONS FOR COMPETITION EQUIPMENT AND COMMERCIAL MARKINGS**

EDITION 2011/12 (September 2011)

**INTERNATIONAL SKI FEDERATION**  
FEDERATION INTERNATIONALE DE SKI  
INTERNATIONALER SKI VERBAND

Blochstrasse 2; CH- 3653 Oberhofen / Thunersee; Switzerland

Telephone: +41 (33) 244 61 61

Fax: +41 (33) 244 61 71

E-mail: [joerg@fisski.com](mailto:joerg@fisski.com)

Website: [www.fis-ski.com](http://www.fis-ski.com)

Oberhofen, September 2011

# TABLE OF CONTENTS

<b>A. Definition</b> .....	<b>1</b>
<b>1. Competition equipment</b> .....	<b>1</b>
1.1 Competition implements .....	1
1.2 Additional equipment (accessories).....	1
1.3 Auxiliary equipment.....	1
<b>2. Commercial Marking on Equipment</b> .....	<b>1</b>
<b>B. Alpine Competition Equipment</b> .....	<b>1</b>
<b>1. Alpine racing skis</b> .....	<b>1</b>
1.1 Definition .....	1
1.2 Restrictions .....	2
1.2.1 Geometric features .....	2
1.2.1.1 Ski length .....	2
1.2.1.2 Profile width.....	3
1.2.1.3 Radius .....	3
1.2.1.4 Overall height of sectional view .....	3
1.2.1.5 Camber .....	3
1.2.1.6 Contour, length and height of shovel .....	3
1.2.1.7 Contour of tail.....	3
1.2.1.8 Running surface .....	3
1.2.1.9 Running Groove .....	4
1.2.2 Flexibility .....	4
1.2.3 Mass.....	4
1.2.4 Construction .....	4
1.2.4.1 Type .....	4
1.2.4.2 Ski components.....	4
1.2.5 Durability .....	4
1.2.6 Additional equipment .....	4
1.2.6.1 No additional equipment is permitted which .....	4
<b>2. Safety bindings</b> .....	<b>4</b>
2.1 Anti-vibration plates .....	4
2.1.1 Width of ski surface.....	4
2.1.2 Maximum height.....	5
2.2 Ski stoppers .....	5
<b>3. Ski boots</b> .....	<b>5</b>
3.2 Thickness of ski boot soles .....	5
<b>4. Ski poles</b> .....	<b>5</b>
<b>5. Racing suits</b> .....	<b>5</b>
5.1 Examination of materials, suits .....	6
<b>6. Crash helmets</b> .....	<b>6</b>
<b>7. Ski goggles</b> .....	<b>6</b>
<b>8. Ski gloves</b> .....	<b>6</b>
<b>9. Back protectors</b> .....	<b>7</b>

9.1	Definition .....	7
9.2	Specifications .....	7
9.3	Recommendation for specifications for children .....	7
<b>C. Nordic Competition Equipment.....</b>		<b>7</b>
<b>1. Cross-Country racing skis.....</b>		<b>7</b>
1.1	Definition .....	7
1.2	Restrictions .....	7
1.2.1	Geometric features .....	7
1.2.1.1	Ski length .....	7
1.2.1.2	Ski width .....	7
1.2.1.3	Tip .....	7
1.2.1.4	Tail .....	8
1.2.1.5	Overall height of sectional view .....	8
1.2.1.6	Same construction .....	8
1.2.2	Flexibility .....	8
1.2.3	Mass.....	8
1.2.4	Construction .....	8
1.2.4.1	Type of construction.....	8
1.2.4.2	Ski components.....	8
1.2.4.2.1	Running surface .....	8
1.2.4.2.2	Top surface .....	8
1.2.4.2.3	Edges .....	8
1.2.5	Durability .....	8
1.2.6	Additional equipment .....	8
1.2.6.1	No additional equipment is permitted which .....	8
<b>2. Cross-Country racing bindings.....</b>		<b>9</b>
<b>3. Cross-Country racing boots.....</b>		<b>9</b>
<b>4. Cross-Country racing poles .....</b>		<b>9</b>
4.1	Definition .....	9
4.2	General rules .....	9
4.2.1	Poles of equal length .....	9
4.2.2	Pole length .....	9
4.2.3	Constant length .....	9
4.2.4	Foreign energy .....	9
4.2.5	Weight .....	9
4.2.6	Construction .....	9
4.3	Technical Specifications .....	9
4.3.1	Grip .....	9
4.3.2	Straps.....	9
4.3.3	Shaft.....	10
4.3.4	Baskets .....	10
4.3.5	Tip .....	10
<b>D. Nordic Competition Equipment.....</b>		<b>10</b>
<b>1. Jumping skis.....</b>		<b>10</b>
1.1	Definition .....	10
1.2	Restrictions .....	10
1.2.1	Geometric features .....	10
1.2.1.1	Ski length .....	10
1.2.1.2	Profile width (see enclosure).....	10
1.2.1.3	Contour, length and height of shovel .....	11

1.2.1.4	Contour of tail.....	11
1.2.1.5	Running surface.....	11
1.2.2	Shape and Flexibility.....	11
1.2.3	Mass.....	11
1.2.4	Construction.....	11
1.2.4.1	Ski components.....	11
1.2.5	Durability.....	11
1.2.6	Additional equipment.....	11
1.2.6.1	No additional equipment is permitted which.....	11
1.2.6.2	Additional weights.....	12
<b>2.</b>	<b>Jumping ski bindings.....</b>	<b>12</b>
2.1	Binding wedges.....	12
2.2	Mounting of the bindings.....	12
<b>3.</b>	<b>Ski Jumping boots.....</b>	<b>12</b>
<b>4.</b>	<b>Ski Jumping suits.....</b>	<b>12</b>
4.1	Material, Fabric.....	14
4.2	Air permeability of the suit material.....	15
4.3	Underwear.....	16
4.4	Examination of materials, suits.....	16
<b>5.</b>	<b>Crash helmets.....</b>	<b>16</b>
<b>6.</b>	<b>Ski goggles.....</b>	<b>16</b>
<b>7.</b>	<b>Ski gloves.....</b>	<b>16</b>
<b>E.</b>	<b>Freestyle competition Equipment.....</b>	<b>17</b>
<b>1.</b>	<b>Definition.....</b>	<b>17</b>
	Competition equipment.....	17
1.1	Competition implements.....	17
1.2	Additional equipment (accessories).....	17
1.3	Auxiliary equipment.....	17
<b>2.</b>	<b>Commercial Markings on Equipment.....</b>	<b>17</b>
2.1.	Freestyle Competition Equipment.....	17
2.2	Freestyle skis.....	17
2.2.1	Definition.....	17
2.2.2	Criteria.....	18
2.2.3	Geometric features.....	18
2.2.4	Ski length.....	18
2.2.5	Profile width.....	18
2.2.6	Radius.....	18
2.2.7	Overall height of sectional view.....	18
2.2.8	Camber.....	18
2.2.9	Contour, length and height of shovel.....	18
2.2.10	Contour of tail.....	18
2.2.11	Running surface.....	18
2.2.12	Running Groove.....	18
2.2.13	Flexibility.....	18
2.2.14	Mass.....	18

2.3	Construction.....	18
2.3.1	Type .....	18
2.3.2	Ski components.....	18
2.3.4	Durability .....	19
<b>3.</b>	<b>Additional equipment.....</b>	<b>19</b>
3.1	Safety bindings .....	19
3.2	Anti-vibration plates .....	19
3.3	Width of ski surface.....	19
3.4	Maximum height.....	19
3.5	Ski stoppers .....	19
<b>4.</b>	<b>Ski boots.....</b>	<b>19</b>
<b>5.</b>	<b>Ski poles .....</b>	<b>20</b>
<b>6.</b>	<b>Competition suits .....</b>	<b>20</b>
6.1	Ski Cross.....	20
6.2	Moguls .....	21
6.3	Aerials .....	21
6.4	Halfpipe.....	21
6.5	Helmets.....	21
<b>7.</b>	<b>Ski goggles.....</b>	<b>21</b>
<b>8.</b>	<b>Ski gloves .....</b>	<b>21</b>
<b>9.</b>	<b>Back protectors .....</b>	<b>21</b>
9.1	Definition .....	21
<b>10.</b>	<b>Competition data and event presentation.....</b>	<b>22</b>
<b>F.</b>	<b>Bibs .....</b>	<b>22</b>
<b>1.</b>	<b>FIS Specifications for Alpine bibs .....</b>	<b>22</b>
1.1	Advertising .....	22
1.2	Numbers .....	22
1.3	Assignment .....	22
1.4	Fabric, Material .....	22
1.5	Elasticity (stretch).....	22
1.6	Seams, Sewing .....	22
<b>2.</b>	<b>FIS Specifications for Cross-Country starting bibs.....</b>	<b>23</b>
2.1	Advertising .....	23
2.2	Numbers .....	23
2.3	Assignment .....	23
2.4	Fabric, material .....	23
2.5	Elasticity (stretch).....	23
3.	FIS Specifications for Ski Jumping starting bibs.....	23

3.1 Advertising .....	23
3.2 Numbers .....	23
3.3 Assignment .....	23
3.4 Fabric, material .....	23
3.5 Elasticity (stretch).....	23
3.6 Seams, sewing.....	23
<b>Procedures for the Acceptance of Innovations in Competition Equipment.....</b>	<b>24</b>
<b>1. Eligible applicants .....</b>	<b>24</b>
<b>2. Items for application .....</b>	<b>24</b>
<b>3. Prototype, samples .....</b>	<b>24</b>
<b>4. Decisions of the Committee for Competition Equipment .....</b>	<b>24</b>
<b>5. FIS Council .....</b>	<b>25</b>
<b>Commercial Markings on Equipment .....</b>	<b>44</b>
1. General Principles .....	44
2. Actual specifications.....	44
2.1 Skis, boots, bindings, ski poles, arm and leg protection, etc. ....	44
2.2 Gloves .....	44
2.3 Goggles .....	44
2.4 Clothing .....	45
2.5 Helmets and Headgear .....	45
2.6 Other sponsors.....	46
2.7 Accessories .....	46
II. By-laws for commercial markings and for advertising.....	47
A. Commercial markings.....	47
A.3 Measuring.....	47
B. Advertising with athletes .....	47
B.3 Not allowed in advertising with athletes: .....	47
C. The above rules also apply in connection with press information or PR activities. ....	47

# Specifications for Competition Ski Equipment

## A. Definition

### 1. Competition equipment

The term „competition equipment“ implies all items of equipment used by athletes in competitive skiing, including clothing and implements that serve a technical function. The entire competition equipment forms a functional unit. In this connection the following points must be observed:

- a) the principle of safety
- b) the principle of fairness

#### 1.1 Competition implements

Competition implements refer to equipment which fulfil essential functions during the competition but which can be separated from the actual competition.

Examples: skis, bindings, boots, poles, clothing, helmets, ski goggles.

#### 1.2 Additional equipment (accessories)

Additional competition equipment (accessories) are those components or implements which exert an influence on the technical function of the competition equipment and which are attached directly to the equipment by means of recognised fastenings. Such accessories do not perform essential functions during the competition.

Example: parablacks, plastic tip covers, additional weights, back protectors.

#### 1.3 Auxiliary equipment

Auxiliary equipment refers to those components of the competition equipment which do not fulfil an essential function, and which do not fall under the heading of additional equipment

Example: measuring instruments.

## 2. Commercial Marking on Equipment

Specifications on pages 44 to 46

## B. Alpine Competition Equipment

### Downhill, Slalom, Giant Slalom, Super G

Measurements are valid only if they have been carried out by appointed FIS equipment measurement experts using official FIS measurement tools.

Measurements are valid at the time of measurement, irrespective of previous measurements.

### 1. Alpine racing skis

#### 1.1 Definition

Skis, predominantly for use in Downhill, Slalom, Giant Slalom and Super-G, racing on suitable terrain and utilising the force of gravity. In order to

allow transmission of lateral forces, the edges of the running surface of the ski are made mainly of a hard material resistant to wear and tear.

Specifications for Alpine Skis as of 2012/13 are published on the FIS website

## 1.2 Restrictions

### 1.2.1 Geometric features

For MAS racers the following specifications in regard to ski length and radius (except Super-G) are recommendations. The minimum ski length for Super-G skis is compulsory for MAS racers.

#### 1.2.1.1 Ski length

Minimum length "developed" length (unwound length) in accordance with ISO Norm including a measurement tolerance of +/- 1 cm. The ski length must be marked on the ski.

##### Downhill

Ladies:	210 cm
Ladies FIS/ENL:	210 cm / -5 cm tolerance
Men:	215 cm
Men FIS/ENL:	215 cm / -5 cm tolerance

##### Super-G

Ladies:	200 cm
Ladies FIS/ENL:	200 cm / -5 cm tolerance
Ladies MAS (Giant Slalom Skis permitted)	180 cm / without tolerance
Men:	205 cm
Men FIS/ENL:	205 cm / -5 cm tolerance
Men MAS (Giant Slalom Skis permitted)	185 cm / without tolerance
Children II:	175 cm

##### Giant Slalom

Ladies:	180 cm
Ladies FIS/ENL:	180 cm / -5 cm tolerance
Ladies MAS:	180 cm / -5 cm tolerance
Men:	185 cm
Men FIS/ENL:	185 cm / -5 cm tolerance
Men MAS:	185 cm / -5 cm tolerance

##### Slalom

Ladies:	155 cm
Men:	165 cm
Men Junior I at FIS and ENL races:	165 cm / -10 cm tolerance
Children I & II:	130 cm

MAS:	No length, width or ski radius restriction for Ladies above 55 and Men above 65 years of age.
------	-----------------------------------------------------------------------------------------------

Precision for the length of Slalom Skis:

When a ski tip different from the main body of the ski is used, the measurement will only be taken into account to the extent it covers a surface corresponding to the natural shape of the ski.

The manufacturer must mark the tip showing the limit of the natural shape and thereby allow an easy measurement.

To prevent doubt, specific designs of ski tips as part of the main body of the ski are allowed.

Recommendation for children younger than 11 years

For children younger than 11 years: Use only one pair of skis in all events if the ski length is shorter than 130 cm.

#### 1.2.1.2 *Profile width*

Minimum width of the running surface at binding without any tolerance.

DH Ladies' & Men:	minimum 67 mm
SG Ladies' & Men:	minimum 65 mm
GS Ladies' & Men:	minimum 65 mm
SL Ladies' & Men:	minimum 63 mm

#### 1.2.1.3 *Radius*

The radius must be marked on the ski.

Downhill Ladies & Men:	minimum 45 m
---------------------------	--------------

Radius measurement for DH skis with a preparation tolerance of -1 m.

Super-G Ladies & Men:	minimum 33 m
Children II:	minimum 27 m

Giant Slalom Ladies:	minimum 23 m
Men:	minimum 27 m
Children II:	minimum 17 m
Children I:	minimum 14 m

#### 1.2.1.4 *Overall height of sectional view*

No limitations.

#### 1.2.1.5 *Camber*

No limitations.

#### 1.2.1.6 *Contour, length and height of shovel*

Slalom and Giant Slalom:	minimum height per ski: 50 mm
Downhill and Super G:	minimum height per ski: 30 mm

#### 1.2.1.7 *Contour of tail*

Maximum height: 10 mm.

#### 1.2.1.8 *Running surface*

No limitations

1.2.1.9 *Running Groove*

No limitations

1.2.2 *Flexibility*

No limitations with regard to the rigidity in all grades of flex.

1.2.3 *Mass*

No limitation with regard to weight and distribution of mass.

1.2.4 *Construction*

1.2.4.1 *Type*

No limitation with regard to composite structure.

1.2.4.2 *Ski components*

Running surface: no limitations with regard to material and dimensions.

Torsion box: no limitations with regard to material and dimensions.

Edges: no limitations with regard to material and dimensions.

Top surface: no limitations with regard to material and dimensions.

Core: no limitations with regard to material and dimensions.

1.2.5 *Durability*

With regard to the mounting of bindings, national norms and at least the „Ö-Norm 4030“, i.e. the equivalent of DIN- and ISO-norms, must be observed.

1.2.6 *Additional equipment*

1.2.6.1 *No additional equipment is permitted which*

- a) makes use of foreign energy (e.g. heaters, chemical energy accumulators, electric batteries, mechanical aids, etc.)
- b) causes or intends to cause changes in the outer conditions of the competition to the disadvantage of fellow competitors (e.g. changes to piste or snow)
- c) increases the risk to the users or other persons, when used for the purpose for which it was intended.

## **2. Safety bindings**

Safety bindings function as strain limiters. That is, these devices transfer specific demands occurring during skiing to an acceptable limit, and when this limit is overstepped, they release their firm hold on the ski.

### **2.1 Anti-vibration plates**

Anti-vibration plates can be mounted if the following conditions are taken into consideration:

2.1.1 *Width of ski surface*

The width of the plates must not exceed the width of the ski surface.

**2.1.2**     *Maximum height*

Maximum height (distance between the bottom of the running surface of the ski and the ski boot sole) for all categories is 50 mm (Ladies, Men and Children's).

**2.2**       **Ski stoppers**

The ski stopper is a braking apparatus for skis, the function of which following the release of the safety binding, is to stop or bring to a standstill the loose ski within the immediate vicinity of the skier's fall. The use of skis without ski stoppers during competitions or official training runs is prohibited. The functioning of the release mechanism must not be compromised by the method of its mounting. It is the manufacturers' responsibility to ensure that the ski stopper functions correctly.

**3.**        **Ski boots**

**3.1**       Ski boots are robust footwear developed specifically for skiing, offering protection against jolts and bumps as well as injury from ski edges and other external influences. The ski boot encloses the foot firmly, while at the same time allowing the movement necessary for skiing techniques, in that the ankle has the room it needs to flex, but at the same time facilitating the transfer of every steering movement completely to the ski.  
The relevant national and international guidelines and norms establish the requirements.

**3.2**       **Thickness of ski boot soles**

Distance between the ski boot sole and the base of the heel including all hard and soft parts:

Ladies, Men, Children I and II	maximum 43 mm
Ladies & Men MAS	maximum 45 mm (Recommendation)

Recommendation for children younger than 11 years

The height of the skis and the boots should be the same as in the categories CHI I and CHI II

**4.**        **Ski poles**

The ski pole is an item of equipment, the function of which is to aid the skier and facilitate balance. National and international rules establish the minimum requirements for ski pole tips, grips, shafts, baskets, straps, length, etc. Owing to risk of injury, metal baskets are not permitted.

**5.**        **Racing suits**

Competition suits and clothing worn underneath, such as underwear, etc., may not be plasticised or treated by any chemical means (gaseous, liquid or solid) and must have a minimum permeability of 30 litres per m<sup>2</sup>/sec. Seams may only exist in order to join the portions of the suit. Outer tucks and darts are not allowed. The suits must be equally porous in all parts, both from the outside in and from the inside out. Minimum air permeability is established whereby the unstretched fabric must show a medium air permeability of a minimum of 30 litres per m<sup>2</sup>/sec under 10 mm of water pressure.

Competitors are allowed to protect all parts of the body with so called protectors in all events:

- In Downhill, protectors may not be integrated into the competition suit itself.
- In all events these protectors must be worn underneath the plombed racing suit. (Exception forearm protection used in SG, GS and SL and shin protection used in SL)

Protectors must fulfil the 30 litre permeability rule with the exception of the shoulder, scapular region, chest, arms and legs. The anatomical body shape may not be changed.

## **5.1 Examination of materials, suits**

The guidelines for minimum air permeability established by the Control Procedures/Equipment Working Groups in collaboration with the Federal Institute for Materials Control are valid. Multi-layered materials are accordingly permitted for alpine racing suits, as long as they conform to the air permeability requirements in question.

## **6. Crash helmets**

The use of crash helmets is compulsory for all events.

Only helmets are permitted whose shell and padding cover the head and ears. The National Ski Associations are advised to provide their teams only with crash helmets which satisfy the minimum requirements for the respective event and which have been certified by recognised institutes.

Helmets with spoilers or edges that protrude are not permitted.

Certain helmets must show a smooth top surface for safety reasons.

Helmets used in FIS Snowsports shall be specifically designed and manufactured for the respective discipline and shall bear a CE mark and conform to recognized and appropriate standards such as CEE 1077 or US 2040, ASTM F2040, SNELL S98 or RS 98, etc.

Soft ear protections are only allowed for SL events.

For alpine speed events (DH/Super G), the helmets must fulfil the following specific additional requirement: the maximum deceleration measured during the impact established based on the test described in the norm EN 1077 Class A must be equal or lower to 230g (NB: according to standard EN 1077 Class A: equal or lower to 250g). The helmet must bear a specific label / marking of minimum 1sqcm applied by the manufacturer on the outside shell and stating "DH/SG" confirming that such requirement is fulfilled.

## **7. Ski goggles**

Ski goggles are devices protecting the eyes against weather and rays with optically correct lenses. Their aim is to guarantee good, contrast-free visibility in all weather conditions. The use of ski goggles is recommended. It is prohibited to reshape the ski goggles in order to obtain aerodynamic advantages.

## **8. Ski gloves**

Gloves offer protective covering against weather and external forces. The wearing of gloves is urgently recommended. Reshaping the glove, the application of a plastic coating on the outer surface, or the use of skai (imitation leather) with the aim of attaining more aerodynamic features, are

not allowed. The glove must not reach beyond the elbow. Protective padding along the entire length of the glove is permitted. The use of protective guards in the form of shields, which are pulled over the glove, is permitted.

## **9. Back protectors**

### **9.1 Definition**

The back protector is an additional item of equipment, which protects the athlete's back against weather and external forces.

### **9.2 Specifications**

The back protector must adapt to the anatomical bend of the athlete's spine and lie flat against the body. The top edge of the back protector must be situated in the area of the spinal column and may not go above the 7th cervical vertebrae (C7). The maximum thickness must be in the middle part and may not exceed 45 mm; the thickness reduces at the edges of the back protector. Designs with the view to improve aerodynamic properties are forbidden. The back protector must be worn underneath the competition suit.

### **9.3 Recommendation for specifications for children**

Children under 11 years should use back protectors (also for CHI I and CHI II)

## **C. Nordic Competition Equipment Cross-Country Skiing**

### **1. Cross-Country racing skis**

#### **1.1 Definition**

The cross-country racing ski is a type of ski, whose features guarantee the best possible application of the gliding techniques to master cross-country pistes (uphills, bumpy terrain, downhills). The basic features of this type of ski are defined in these rules.

#### **1.2 Restrictions**

##### *1.2.1 Geometric features*

##### *1.2.1.1 Ski length*

Minimum: height of skier minus 100 mm

##### *1.2.1.2 Ski width*

In the binding fixation area of the ski defined by ISO 9119 or Ö-Norm S4072

Minimum 40 mm

##### *1.2.1.3 Tip*

The minimal shovel curvature is 30 mm.

- 1.2.1.4 *Tail*  
The tail must not rise more than 30 mm on the unweighted ski when laying on a flat surface.
- 1.2.1.5 *Overall height of sectional view*  
Maximum 35 mm  
Minimum 20 mm
- 1.2.1.6 *Same construction*  
Both skis must be constructed in the same way, and must be the same length.
- 1.2.2 *Flexibility*  
No restrictions with regard to the rigidity in all grades of flex.
- 1.2.3 *Mass*  
Skis must weigh at least 750 g per pair. No limitations with regard to the distribution of mass.
- 1.2.4 *Construction*
- 1.2.4.1 *Type of construction*  
No limitations.
- 1.2.4.2 *Ski components*
- 1.2.4.2.1 *Running surface*  
The entire width of the running surface can be smooth or slightly grooved length-wise. With the exception of the running groove, however, the level must be constant in the entire length and width. Climbing aids in the form of scale patterns or step patterns are permitted. Models driven by means of foreign energy of any kind are not permitted.
- 1.2.4.2.2 *Top surface*  
No limitations
- 1.2.4.2.3 *Edges*  
The edges must not face up and outwards, making the running surface narrower than the top surface (no wedge shape).
- 1.2.5 *Durability*  
No limitations
- 1.2.6 *Additional equipment*
- 1.2.6.1 No additional equipment is permitted which
- a) makes use of foreign energy (e.g. heaters, chemical energy accumulators, electric batteries, mechanical aids, etc.)
  - b) causes or intends to cause changes in the outer conditions of the competition to the disadvantage of fellow competitors (e.g. changes to piste or snow)

- c) increases the risk of injury to users or other persons, when used for the purpose it was intended for.

## **2. Cross-Country racing bindings**

No limitations with regard to material and make, subject to decisions 1.2.6 b) and c).

## **3. Cross-Country racing boots**

No limitations with regard to material and make.

## **4. Cross-Country racing poles**

### **4.1 Definition**

The cross-country racing pole is a pole, whose features guarantee the best possible application of the gliding techniques to master cross-country pistes (uphills, bumpy terrain, downhill).

### **4.2 General rules**

#### *4.2.1 Poles of equal length*

Two poles of equal length must be used in competition, with one pole held in each hand.

#### *4.2.2 Pole length*

The maximum pole length must not exceed the competitor's height, nor measure below the hips (measurements are taken by placing the tip of the pole on the ski in front of the binding).

#### *4.2.3 Constant length*

The pole must have a constant length. It may not, for example, possess a telescopic system.

#### *4.2.4 Foreign energy*

The pole must not create a foreign energy to favour push-off (e.g. springs or mechanical devices).

#### *4.2.5 Weight*

No limitations regarding the weight of the pole.

#### *4.2.6 Construction*

The poles may be constructed asymmetrically (e.g. there may be a difference between left- and right-hand poles).

### **4.3 Technical Specifications**

#### *4.3.1 Grip*

The grip must be attached to the shaft. There are no limitations with regard to geometric features or material.

#### *4.3.2 Straps*

The straps must be joined to the grip or the shaft. They may be adjustable in length and width.

**4.3.3**     *Shaft*

There are no limitations with regard to material and make of the shaft or distribution of mass.

**4.3.4**     *Baskets*

Baskets with varying geometric features and materials are permitted to master various snow conditions. The baskets, however, must not change the condition of the track, so that other competitors suffer disadvantages.

**4.3.5**     *Tip*

Tips may be joined to the shaft at any angle. It is permitted to use one or more tips per pole. There are no limitations with regard to material.

**D.       Nordic Competition Equipment**  
**Ski Jumping**

**1.       Jumping skis**

**1.1     Definition**

Jumping Skis are manufactured especially for use on Ski Jumping hills. Their construction is adapted to the requirements of Ski Jumping.

**1.2     Restrictions**

**1.2.1   Geometric features**

**1.2.1.1   Ski length**

According to the body weight/height relationship ( $BMI = \text{body weight} / \text{body height}^2$  in  $\text{Kg/m}^2$ ). See enclosure.

However, the maximum ski length is 145 % of the total body height of the competitor a minimum BMI of 20.5 for Ladies and 21 for Men has to be reached. For athletes with less than minimum BMI a grading table of 0,125 BMI per 0,5 % of ski length will be applied.

Exception:

For Youth competitions, the maximum ski length is limited to 140 % from the body height only (no BMI formula will be applied).

**1.2.1.2   Profile width (see enclosure)**

The curvature from A through B to C indicates the shape of the ski side cut. This curvature must be equal on both sides and symmetrical to the ski centre line. As a maximum the line connection from A to B, as well as B to C should appear as a straight line.

Minimum width of the running surface at the point of balances 95 mm, maximum width 105 mm.

The edges must form a 90° angle to the running surface and the top surface along the entire length of the ski.

Rounded top-to-bottom edges must never be more than 2 mm.

The difference between the above-mentioned measurement of the width of the ski tip and the ski tail may not exceed 5 mm.

**1.2.1.3** *Contour, length and height of shovel*

The ski tip may be individually modified as long as it remains symmetric and centred to the middle part and that the minimum distance to the ground of 30 mm is observed.

**1.2.1.4** *Contour of tail*

According to the sketch (see page 39)  
Maximum height 10 mm

**1.2.1.5** *Running surface*

Running surface must be flat and may have a fine base structure in a longitudinal direction. With the exception of the grooves, the entire ski base cannot have any additional shapes. There can be one or more grooves; however the total of the measured surface area of all the grooves may not exceed 50% of the minimal width of the ski. The width of a single groove may not exceed 10 mm. The base must be of a polyethylene material.

**1.2.2** *Shape and Flexibility*

Aerodynamic coverings on the tips, as well as fins in the form of stabilizers on all sides are not allowed. A design, which makes a desired aerodynamic flex possible during flight, is not allowed. Otherwise there are no limitations with regard to rigidity in all grades of flex. The top surface of the ski must be smooth and flat.

**1.2.3** *Mass*

A single non-mounted ski must have a minimum weight conforming to its length (the weight in dkg results of the ski length in cm: e.g. 250 cm = 2,50 Kg, 262 cm = 2,62 Kg). Lead-weights used for balancing the centre of gravity are not considered (see 1.2.6.2).

**1.2.4** *Construction*

**1.2.4.1** *Ski components*

Torsion box: No limitations with regard to material and dimensions.  
Edges: see 1.2.1.2.

**1.2.5** *Durability*

The jumping ski must have screw retention strength of 1600 N in the area of the binding mounting.

**1.2.6** *Additional equipment*

**1.2.6.1** *No additional equipment is permitted which*

- a) makes use of foreign energy (e.g. heaters, chemical energy accumulators, electric batteries, mechanical aids, etc.).
- b) causes or intends to cause changes in the outer conditions of the competition to the disadvantage of fellow competitors (e.g. changes to piste or snow).
- c) increases the risk of injury to users or other persons, when used for the purpose it was intended for.

**1.2.6.2 Additional weights**

Additional weights for balancing the centre of gravity are permitted.

**2. Jumping ski bindings**

Safety bindings in Ski Jumping function as strain limiters. That is, these devices transfer specific demands occurring during skiing to an acceptable limit, and when this limit is overstepped, they release their firm hold on the ski.

Additional devices creating foreign energy of any kind as an aid to take-off are forbidden.

The complete binding system must be mounted so, that the Ski Jumping shoes are fixed to the skis symmetrically, parallel and centrally to the running direction. After fixing the front part of the jumping shoe into the front part of the binding it must stay fixed and horizontal to the top surface of the ski. The outline of the heel wedge of the shoe sole in its normal production form may not protrude over the side-walls of the Jumping ski.

**2.1 Binding wedges**

Binding wedges are permitted to improve the in run position. The entire height of the boot sole and binding wedge must not exceed 70 mm.

**2.2 Mounting of the bindings**

The binding must be mounted in such a way that maximum 57% of the entire ski length is used as the front part. Measured from the ski tip (with shovel curvature) to the shoe cap (leather part). (The 57% will be rounded up or down to full centimetres).

**3. Ski Jumping boots**

The shoe size and form must equal the foot size and form. Reshaping the boots in order to attain more aerodynamic features is not allowed. The boot sole may not exceed 45 mm.

**4. Ski Jumping suits**

All portions of the ski jumping suit must be made of the same material (see 4.2) and must show the same air permeability from the outside in and from the inside out.

The suit must close by means of a zipper placed at the centre of the front, which reaches to the collar. The maximum zip length is allowed to the cross part of the crotch. The width of this zipper may not exceed 15 mm. During the jump the zipper must be completely closed. The design of the suit (seams) must conform to the image "Ski Jumping Suits" in the enclosure.

The maximum tolerance in the size of the suit is 6 cm over the body size at any part of the suit. Minimum: at least body size (non stretched).

It is not allowed to connect or attach the sleeves of the suit to the gloves.

Exception is to accommodate the fit of the suit around the boot, a maximum tolerance of 10 cm is given and the anterior crotch length, where no tolerance is permitted.

Additional restrictions

- Marking of the suit (for measuring and control) is allowed.

- The thickness of all parts of the suit must be the same.
- No additional chemical (gaseous, liquid or solid) or mechanical treatment of the material or suits is allowed.
- The collar of the Jumping suit may have a tolerance and not exceed 8 cm in regarding the measurement of the throat. The collar of the suit must be ended by a non elastic seam band. The collar of the suit must be placed no higher than the joint of the collar bones (see the illustration - mark X). The height difference between the front and the back of the collar may not exceed 5 cm (see the illustration - mark X1 and X2).
- Outer tucks and darts, folds and padding are not allowed.
- Only one fixed (non-adjustable) strap per leg is allowed for fixing the suit around the ski boot. The strap is of one continuous piece and without clips, buckles or other means of fastening multiple pieces of material. The fixation of either strap must be made at the hem of the suit (see the illustration - mark S).
- Length of the sleeve maximally to the wrist joint. The lower hem of the sleeve is cut evenly and has no integrated hole for fingers.
- All hems must be sown by a singular piece and the entire piece must have the same physical material characteristics.
- Standardized measuring control points:
  - Anterior arm length (see the illustration - mark AL) is measured from the intersection of the seams at the armpit, following the seam to the end of the sleeve. Measured length must be no greater than the length of the arm and no shorter than a maximum tolerance of 6 cm.
  - Anterior crotch length (see the illustration - mark SL) is measured from the intersection of the seams at the crotch of the suit (see the illustration - mark SX) following the anterior seam to the hem of the leg part of the suit.

Measured length of the suit must be no shorter than the measured length of the controlled crotch height.

- Number of parts of the material of which the suit consists is:
  - 2 for each sleeve including shoulder: front part of the sleeve (see the illustration - mark 3) and back part of the sleeve (see the illustration - mark 5). Each sleeve starts from the neck opening and extends over the shoulder to maximally the wrist joint. Starting from the armpit down the size of the panels must be equal front and back. The alignment of the posterior seam must be centered along the length of the sleeve and parallel to the torso seam. In addition, when the arm is extended from the torso, the anterior seam of the sleeve must be aligned with the torso seam.
  - 5 for the torso (upper body above the waist seam): left and right front panels (see the illustration - mark 1), left and right side panels (see the illustration - mark 7). Each side panel must be a minimum of 10 cm in width and no greater than 15 cm in width.
  - 2 for each leg (under the waist seam): the front leg panels (see the illustration - mark 2) and the back leg panels (see the illustration - mark 6). Starting from the crotch down, the size of the panels must be equal front and back. The alignment of the posterior and anterior seams is entered along the length of the leg. The front and back crotch seams must connect with the anterior leg seams at the lowest point of the crotch (see the illustration - mark SX).

- Zipper, elastics and strings for the attachments do not count as a separate part of the suit.
- The waist seam must be placed in relationship to the body within 10 cm above the hip bone (narrow part of the waist). The seam must go around the torso horizontally.
- The seam connecting the upper front and side panel must align vertically with the seam of the leg panels from the armpit to the posterior ankle bone, when the athlete is wearing it in an upright position.
- The bottom hem of the leg panels may be altered to accommodate the fixing of the binding at the heel of the boot.
- Seams may only exist in order to join the portions of the suit. Seams must be inside the suit. It is not allowed to edge-stitch (sew) the ends of the material; it is not allowed to join (sew) the maximum seam of 20 mm (material behind the seam to the edge). All seams must be straight or formed differently only to fit the form of the body. Any additional seams or transformation of the seams, any strings, rods, folds, tapes, etc., inside or outside the suit in order to attain greater volume or more aerodynamic features is not allowed (the same for the underwear).
- The enclosed suit illustrations are the determining bases for these written rules. Exception for Youth competitions: no limit for number of parts and cutting of the suits.

Additional specifications for the Ladies Ski Jumping suit:

- Side parts (Pos. 4 and Pos. 7)  
Both the side parts end at the height of the athlete's knee (both parts end at the same height). The tolerance for the end of both parts, above and below the knee, is +/- 15 cm. The front seam from the side part 7 must run over the middle part of the breast.
- Upper front parts (Pos 1)  
The upper and lower areas of front part 1 (Position A1 and A2 on the sketches) must have a width of at least 10 cm.
- Back parts (Pos 6 and Pos. 8)  
The waist seam between the back parts must be located at the smallest position of the waist and must be straight.
- Front parts (Pos 1 and Pos 2)  
The seam between part 1 and part 2 must start at least 10 cm lower (+/- 2 cm tolerance) than the waist seam on the backside. The end of the seam in the middle must end 6 cm lower as the start point (+/- 1 cm). Both parts of the seam (Pos 1) must end at the same height.
- Front and back parts (Pos 2 and Pos. 6)  
The parts 2 and 6 must be at least 10 cm wide at every position.

#### **4.1 Material, Fabric**

The structure of the surface of the material and the composition of the material for all parts of the suit must be the same. The only exceptions are different colours of the same material.

The thickness of the suit may not exceed 5.0 mm, nor be less than 4.0 mm.

Construction of the Ski Jumping suit is a five-layer laminated fabric and consists of:

- outer fabric/ first layer

- foam
- elastic membrane
- foam
- lining fabric

The components are laminated together by either a hot-melt process or flame laminated, where 4 acts are necessary to laminate the fabric.

The controlled air permeability of 40 l/m<sup>2</sup>/sec. (FIS Rules) is reached by perforation and guarantees a constant value.

#### *Outer fabric / first layer*

The outer fabric for the ski jumper laminate is a bi-elastic warp-knit fabric, called Charmeuse (pattern notation). This material is produced on a 2-thread system warp knitting machine.

#### Material:

81 % Polyamid gloss dtex 44f12

19 % Elasthane (Lycra) dtex 44f1

#### Weight:

180/190 g/m<sup>2</sup> approx.

#### Elasticity:

Length 150-160%

Width approx. 85-95%

#### Finishing:

The quality is dyed in a classical piece dying method (acid dyestuff). Beside the dyestuff and eventual dyeing assistant there is no use of other chemical stuff allowed, which would change the characteristics of the surface.

Material has two different sides:

- a) Lengthwise stripe "rip fabric (even side)"
- b) Transverse thread connection, called satin-side

The satin side is the visible outside of the jumping suit. The satin side must be chinzed. There are no other additional treatments like chemical or mechanic surface changes allowed (for example by aluminium steam, foil application, shaping or others).

#### **Lining fabric**

Lining fabric is identical with the outer fabric (material and weight) but only white.

#### **Inside fabric / foam and elastic membrane**

The inner life of the material is a three-layer laminate built up of a two 2,1 mm foam layers (volumetric weight ca. 55g) and with an elastic membrane in the middle. This laminate is perforated to reach the defined air permeability.

#### **4.2 Air permeability of the suit material**

The material of a jumping suit must show a minimum air permeability which is the same from the outside in and from the inside out. Minimum air permeability is established as follows:

The unstretched fabric must show a medium air permeability of a minimum of 40 litres per m<sup>2</sup>/sec with 10 mm water pressure.

This value is compulsory at the time of distribution by the manufacturer that means at the moment of plumbing. At controls in competitions it must not be less than 40 litres.

Although usage may result in some stretching of the material, the back portion of the suit must show air permeability as high or higher than the other parts of the suits.

#### **4.3 Underwear**

- The thickness of the underwear must not exceed 3,0 mm (cumulative - all layers and parts of the underwear together).
- Air permeability of the underwear must exceed 60 l/m<sup>2</sup>.
- The size, fit and form of underwear must conform the size and shape of the body. Up to a maximum over size tolerance of 10 cm at any measurable body part is permitted.
- No form of a hood is allowed.

#### **4.4 Examination of materials, suits**

The guidelines for minimum air permeability established by the FIS Control Procedures/Equipment Working Group in collaboration with the Federal Institute for Materials Control are valid.

Multi-layered materials are accordingly permitted for Ski Jumping suits, as long as they conform to the technical specifications and air permeability requirements and all portions of the suit are made from the same material.

### **5. Crash helmets**

The use of crash helmets is compulsory for all events. The shape of the helmet must conform to the shape of the head. The shell and padding shall completely cover the head and ears. The shell does not need to extend to the ears which shall however be adequately covered and protected (soft ear padding permitted).

The distance measured at any point between the outside surface of the helmet and the head shall not exceed 7 cm.

The surface (shell) of the helmet shall be smooth for safety reasons.

Helmets with visors or integrated face shields, detachable or not are not permitted.

The helmets used shall conform to recognized safety standards adapted for Ski Jumping including CEE 1077 or US 2040. Conformity to standard shall be attested by a marking/label affixed on or inside the helmet.

### **6. Ski goggles**

Ski goggles are devices protecting the eyes against weather and rays with optically correct lenses. Their aim is to guarantee good, contrast-free visibility in all weather conditions. The use of goggles is recommended. Reshaping the ski goggles in order to attain more aerodynamic features is not allowed.

### **7. Ski gloves**

Gloves offer protective covering against weather and external forces. The use of gloves is urgently recommended.

The glove size must correspond to the hand size. Thickness of the material is maximally 5mm.  
Only gloves with fingers (for all fingers) are allowed. The gloves may not be fin-shaped.

## **E. Freestyle competition Equipment**

### **1. Definition**

Competition equipment

The term „competition equipment“ embraces all items of equipment used by the athletes in competition skiing, including clothing and implements that serve a technical function. The entire competition equipment forms a functional unit. In this connection the following points must be observed:

- a) The principle of safety
- b) The principle of fairness

#### **1.1 Competition implements**

Competition implements refer to those parts of the equipment, which fulfil essential functions for the competition and which are separable from the competition.

Examples: skis, bindings, boots, poles, clothing, helmets, ski goggles.

#### **1.2 Additional equipment (accessories)**

Additional equipment (accessories) to competition equipment are those components or implements which have an influence on the technical function of the competition equipment and which are attached directly to the equipment by means of recognised fastenings. Accessories do not perform essential functions for the competitions.

Example: plastic tip covers, additional weights.

#### **1.3 Auxiliary equipment**

Auxiliary equipment refers to those components of the competition equipment which do not fulfil an essential function, and which do not fall under the heading of additional equipment.

Example: measuring instruments.

## **2. Commercial Markings on Equipment**

Specifications on page 44 - 46 and refer to ICR 207.

### **2.1. Freestyle Competition Equipment**

Only measurements which are carried out by the appointed FIS equipment measurement experts using the official FIS measurement tools are valid.

The results of measurements carried out at the time are valid and final, irrespective of previous measurements.

### **2.2 Freestyle skis**

#### *2.2.1 Definition*

Skis employed in Freestyle competition events where the principal source of motive power is gravity. To assist with directional and speed control, the

edges of the running surface are constructed from hard materials and sealed into the ski.

2.2.2 *Criteria*

2.2.3 *Geometric features*

There are no limitations or restrictions for ski length and radius.

2.2.4 *Ski length*

No limitations. (See 4306.1.1 is, 4206.1.1)

2.2.5 *Profile width*

No limitations

2.2.6 *Radius*

No limitations

2.2.7 *Overall height of sectional view*

No limitations.

2.2.8 *Camber*

No limitations.

2.2.9 *Contour, length and height of shovel*

No limitations

2.2.10 *Contour of tail*

No limitations.

2.2.11 *Running surface*

No limitations.

2.2.12 *Running Groove*

No limitations.

2.2.13 *Flexibility*

No limitations with regard to the rigidity in all grades of flex.

2.2.14 *Mass*

No limitation with regard to weight and distribution of mass.

**2.3 Construction**

2.3.1 *Type*

No limitation with regard to composite structure.

2.3.2 *Ski components*

Running surface: no limitations with regard to material and dimensions.

Torsion box: no limitations with regard to material and dimensions.

Edges: no limitations with regard to material and dimensions.

Of top surface: no limitations with regard to material and dimensions.

Core: no limitations with regard to material.

#### 2.3.4 *Durability*

With regard to the mounting of bindings, national norms and at least the „Ö-Norm 4030“, that is the equivalent of DIN- and ISO-norms, must be fulfilled.

### 3. **Additional equipment**

No additional equipment is permitted which

- a) makes use of foreign energy (e.g. heaters, chemical energy accumulators, electric batteries, mechanical aids, etc.)
- b) causes or intends to cause changes in the outer conditions of the competition to the disadvantage of fellow competitors (e.g. changes to piste or snow)
- c) increases the risk for the users or other persons, when used for the purpose it was intended for

#### 3.1 **Safety bindings**

Safety bindings function as strain limiters. That is, these devices transfer specific demands occurring during skiing to an acceptable limit, and when this limit is overstepped, they release their firm hold to the ski. (See 4306.1.2, 4206.1.2, 4008.2.2)

#### 3.2 **Anti-vibration plates**

Mounting of such plates is permitted under the following conditions:

#### 3.3 **Width of ski surface**

The plates may not exceed the width of the ski surface.

#### 3.4 **Maximum height**

For FIS, ENL, Children I and Children II events the maximum height is 50 mm.

#### 3.5 **Ski stoppers**

The ski stopper is a catching apparatus for skis, whose function is to stop or bring to a standstill the loose ski following the release of the safety binding within the intermediate area of the skiers fall. In competitions and official training skis without ski stoppers are not permitted. Ski Stoppers must be mounted in such a way as not to impede the operation of the device. The manufacturer is responsible for a perfect function of the ski stoppers.

### 4. **Ski boots**

Ski boots are robust footwear developed especially for skiing, offering protection against jolts and bumps as well as injury from ski edges and other external causes. The ski boot encloses the foot firmly, while at the same time allowing the movement necessary for skiing techniques, in that the ankle has the room it needs to move, but at the same time allowing the transfer of every steering movement completely to the ski.

The relevant national and international guidelines and norms establish the requirements.

Thickness of ski boot soles

Distance between the ski boot sole and the base of the heel including all hard and soft parts:

Ladies & Men

maximum 43 mm

## **5. Ski poles**

The ski pole is a sports article whose function should aid the skier, facilitate balance and, if necessary, enable stopping. The national and international guidelines and norms establish the minimum requirements for ski pole tips, grips, shaft, baskets, straps, length, etc. Due to risk of injury, metal baskets are not permitted.

## **6. Competition suits**

### **6.1 Ski Cross**

(From Freestyle ICR Ski Cross 4511.4)

#### **Ski suits**

Ski suits must be two pieces; pants and a separate top.

Suits worn in the Alpine events of Downhill (DH), Super-G (SG), Giant Slalom (GS), Slalom (SL) and Speed Skiing are not allowed.

Suit base material shall be textile fabrics excluding rubber, neoprene, leather or vinyl like materials or fabrics. Patches of different material are allowed provided that textile fabrics shall remain, in any event, predominant.

Non-protruding body protection and padding is recommended.

Protection equipment including back protector or any other padding or body armour must be worn on the body and separate from the ski suit (outer wear). Protection and padding must not be built into the ski suit or attached to the ski suit by a zipper, Velcro or any other means. Fastening devices such as elastic straps, zippers, nylon straps, buttons, snaps, velcro, one or 2 sided tape, or any other methods shall not be used to tighten the suit material closer to the body or prevent the natural fall of the clothing.

The gap in the material must be a minimum of 80mm, measured everywhere around the circumference of each leg from the mid thigh to the top of the ski boot and 60 mm everywhere around the elbow and the bicep.

#### **Ski Suit Measurement Method**

Body position and stance for taking measurements:

Any competitor shall appear in full race wear with ski boots on. They shall stand with feet shoulder-width apart, in an upright standing position with arms relaxed at the sides and the legs relaxed forward into the support of the cuffs of their boots. ("full race wear" includes all under layers and padding that is worn while competing.)

The measurement shall take place before or after each qualification run, as decided by the Jury and announced at the First Team Captains Meeting. The measurement shall take place after each heat in the KO Final by first measuring each eliminated competitor prior to exiting the finish area. All competitors in the Final and Small Final heats will be measured prior to exiting the finish area.

The material gap shall be found everywhere at the measuring control points, without stretching or pulling the fabric apart from the underwear. The measurement tool shall be certified through the FIS Office.

Standardized measuring control points:

Lower Body:

Anywhere below the person's mid point of the thigh to the bottom of the pant leg.

The pant leg must cover the top of the skier's boot (top of ski boot is the area directly above the upper most buckle of the boot)

Upper Body:

Mid-bicep (mid-bicep is found by finding the mid-point between the tip of one's elbow and the point on the top of the shoulder where the Acromion bone in the shoulder meets the head of the Humerus.)

## **6.2 Moguls**

No limitations.

## **6.3 Aerials**

No limitations.

## **6.4 Halfpipe**

No limitations.

## **6.5 Helmets**

The use of helmets is compulsory for all events. (See ICR 3054.6, 4008.2.1, 4306.1.3, 4206.13, 4511.3)

The National Ski Associations shall require their athletes to use helmets which conform to recognized and appropriate standards including CEE 1077 or US 2040, ASTM F2040, etc.

## **7. Ski goggles**

Ski goggles are devices protecting the eyes against weather and rays with optically correct lenses. Their aim is to guarantee good, contrast-free visibility in all weather conditions. The use of ski goggles is recommended.

## **8. Ski gloves**

Gloves offer protective covering against weather and external forces. The wearing of gloves is strongly recommended. Protective padding along the entire length of the glove is permitted. The use of protective guards in the form of shields, which are pulled over the glove, is permitted.

## **9. Back protectors**

### **9.1 Definition**

The back protector is an additional item of equipment, which protects the athlete's back against weather and external forces. The use of back protections is recommended.

## **Specifications**

The back protector must adapt to the anatomical bend of the athlete's spine and lay flat against the body. The top edge of the back protector has to be situated in the area of the spinal column. Fastening of the back protector may take place with a stomach belt, straps or suspenders. The maximum thickness has to be in the middle part and may not exceed 45 mm; the thickness reduces towards the edges of the back protector. The back protector may be worn exclusively under the competition suit.

## **10. Competition data and event presentation**

For the purpose of improved television presentation and the technical development of the event, the Freestyle Committee has introduced the collection of digital information on the performance competitor with the use recorders and transmission devices worn by the competitor using systems approved by Freestyle Committee and the Equipment Committee.

### **F. Bibs**

Alpine:  
Downhill / Slalom / Giant Slalom / Super G

Nordic:  
Cross-Country / Ski Jumping

Examples: See Enclosure

#### **1. FIS Specifications for Alpine bibs**

##### **1.1 Advertising**

According to "FIS Advertising Rules"

##### **1.2 Numbers**

According to "FIS Advertising Rules"

##### **1.3 Assignment**

Bibs must be assigned as follows:

Ladies sizes:	with elastic band
Men's sizes:	with elastic band

##### **1.4 Fabric, Material**

T-shirt style bibs, 100% Polyester / Interlock

##### **1.5 Elasticity (stretch)**

Measured on a piece of material 10 cm wide:  
Stretch ability in the width 24 cm.

##### **1.6 Seams, Sewing**

Side seams: Material is sewn together, hemmed and stitched - overlock.  
Neckline and armholes are trimmed with edging and double-stitched.  
Waistband with 2 cm wide seam, double-stitched with an elastic band pulled through. (See enclosure)

## **2. FIS Specifications for Cross-Country starting bibs**

### **2.1 Advertising**

According to "FIS Advertising Rules"

### **2.2 Numbers**

According to "FIS Advertising Rules"

### **2.3 Assignment**

Starting bibs must be assigned as follows and must be cut in such a way that the skier's shoulders are allowed free movement:

Ladies size:	without elastic band
Men's size:	without elastic band.

### **2.4 Fabric, material**

T-shirt starting bibs in smooth material quality 100% Polyester / Interlock or 100 % polyester knitwear (meshed or non-meshed).

### **2.5 Elasticity (stretch)**

Meshed starting bibs: measured on a piece of fabric 10 cm wide:

Stretch ability in the width 18,5 cm

None meshed starting bibs: measured on a piece of fabric 10 cm wide:

Stretch ability in the width: 24 cm (see enclosure)

## **3. FIS Specifications for Ski Jumping starting bibs**

### **3.1 Advertising**

According to "FIS Advertising Rules"

### **3.2 Numbers**

According to "FIS Advertising Rules"

### **3.3 Assignment**

Starting bibs are assigned to the men in men's sizes.

### **3.4 Fabric, material**

T-Shirt starting bibs 100 % Polyester with an air permeability of 40 litres per m<sup>2</sup>/sec under 10 mm of water pressure.

### **3.5 Elasticity (stretch)**

Measured on a piece of fabric 10 cm wide:

Stretch ability in the width 24 cm.

### **3.6 Seams, sewing**

Side seams: material is sewn together, hemmed and stitched - overlook.

Neckline and armholes are trimmed with edging and double-stitched.

Waistband with 2 cm wide seam, double-stitched (see enclosure).

## **Procedures for the Acceptance of Innovations in Competition Equipment**

### **Article 222.4 of the ICR reads as follows:**

New developments must be submitted by May 1<sup>st</sup>, at the latest, for the following season. During the first year new developments can only be approved provisionally for the following season and must be definitively approved prior to the subsequent competition season.

### **1. Eligible applicants**

- a) Manufactures or distributors of the innovation
- b) National Associations
- c) Members of the Committee for Competition Equipment

### **2. Items for application**

Any significant innovation or further development of existing products which is to be used as equipment in competition skiing, may be submitted for acceptance. It is solely the responsibility of the Committee for Competition Equipment to decide whether an innovation or further development conforms to the FIS „Competition Equipment Specifications“. The Committee can at any time, however, arrange the execution of an application with regard to items of equipment to be used in competition sport, in accordance with the decisions of these guidelines.

### **3. Prototype, samples**

The application must include a detailed description of the innovation. A prototype or sample must be submitted with the application. Relevant reports by scientific experts, as well as reports of experiences made by trainers or participants are to be submitted.

### **4. Decisions of the Committee for Competition Equipment**

The Committee for Competition Equipment deals with these applications at its next meeting. If the Committee is of the opinion that the item being presented conforms fully to the valid Specifications for Competition Equipment, this decision will be recorded in a relevant decision.

If the Committee reaches the conclusion that the innovation could be accepted in accordance with the relevant principles and decisions of the FIS Specifications for Competition Equipment in competition sports, the innovation can be provisionally approved for testing for the duration of the following season.

This approval can, however, also be conditionally accepted. On the grounds of fairness, exceptions can be made for certain competitions (Olympic Winter Games, World Championships, etc.).

However, the Committee for Competition Equipment can also take the following measures before provisional approval. These can be dealt with individually or together:

- a) requesting further information from the applicants, such as reports by experts and technical data
- b) seeking reactions of the FIS Technical Committees. These opinions must be submitted in writing and take the following factors into consideration:
  - 1. explanation with regard to the usefulness and necessity of the innovation
  - 2. opinions with regard to the safety of the innovation
  - 3. assurance that in accepting the innovation, the principle of fairness will be guaranteed
- c) soliciting reports by experts and further information through the Committee for Competition Equipment itself.

Should the innovation not conform to the principles of the FIS Specifications for Competition Equipment, either through the application itself, or during the course of the procedures, the use of the innovation in question will be forbidden for competition sport. This will also occur if, during the item's probation period, circumstances result which lead the Committee to decide that the innovation does not conform to the principles of the FIS Specifications for Competition Equipment. In such a case, the provisional approval will be rescinded, with immediate effect.

## **5. FIS Council**

Changes in the Specifications for Competition Equipment can be proposed to the FIS Council only through the Committee for Competition Equipment - either by means of an initiative from the Committee itself or through an application of one of the National Ski Associations or Technical Committees to the Committee for Competition Equipment.

## Ski Jumping

Ski Jumping - Men:  
without elastic band

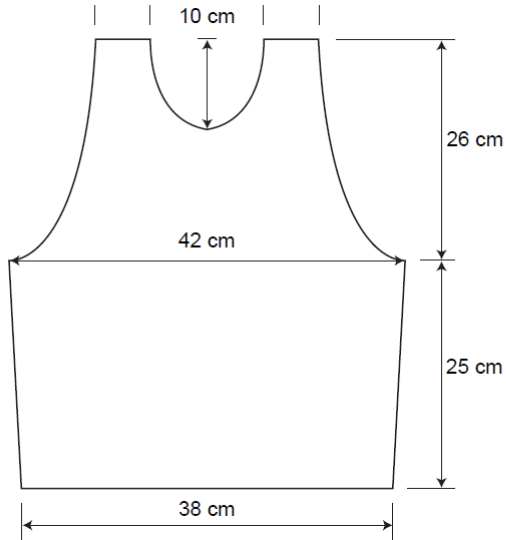

Ski Jumping - Ladies:  
without elastic band

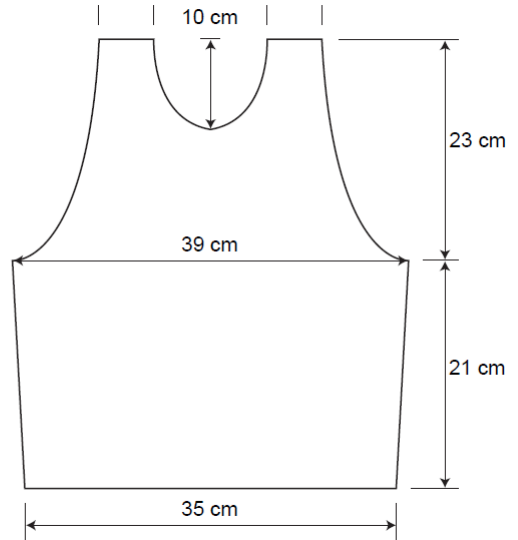

---

## Alpine

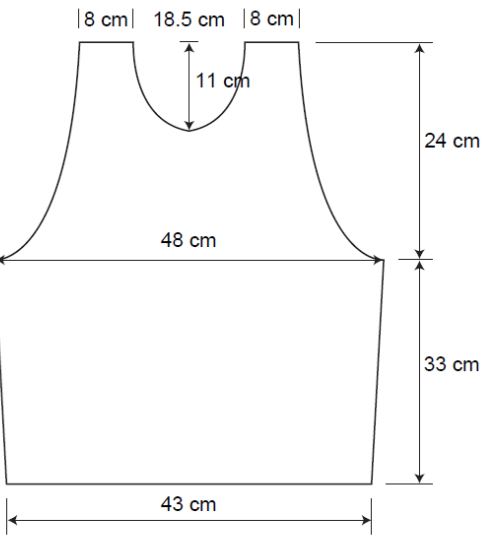

Alpine - Men:  
with elastic

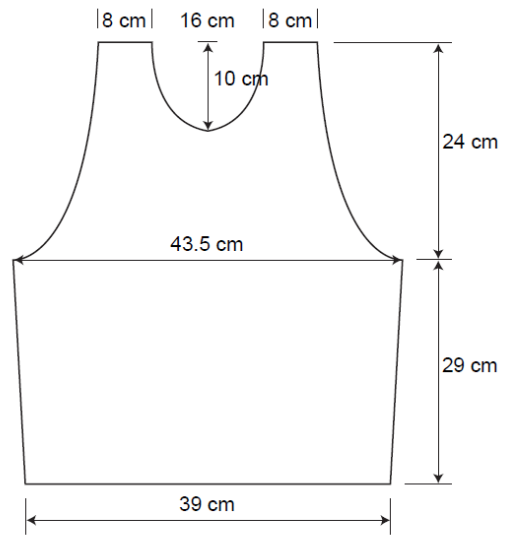

Alpine - Ladies:  
with elastic

## Freestyle Bibs

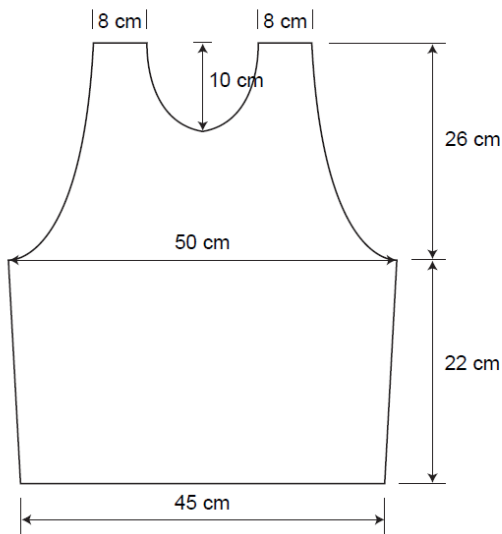

Aerials - Men:  
with elastic band

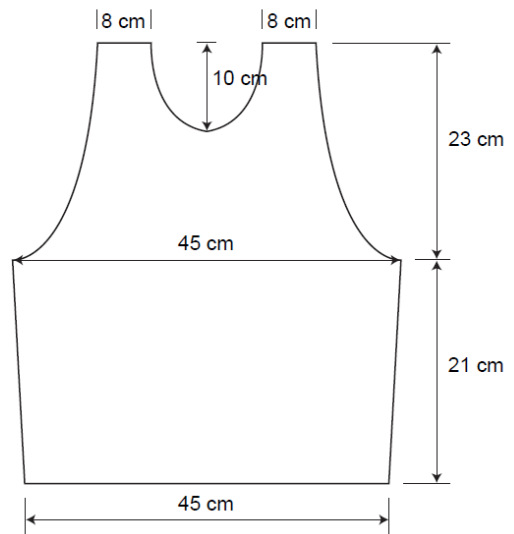

Aerials - Ladies:  
with elastic band

Moguls, Halfpipe, Ski Cross - Men:  
open sides and 4 elastic straps

Moguls, Halfpipe, Ski Cross - Ladies:  
open sides and 4 elastic straps

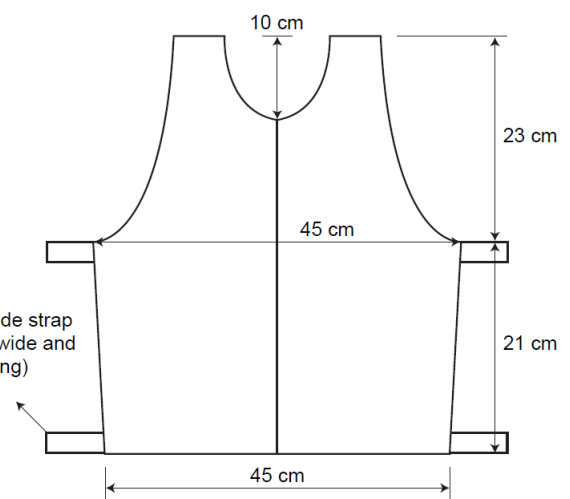
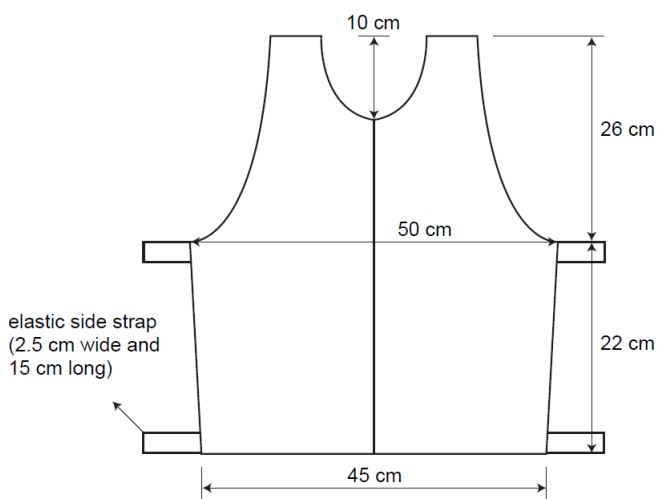

## Cross Country

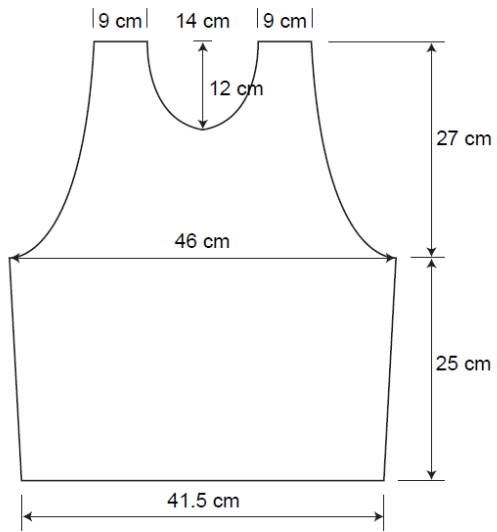

Cross-Country - Men

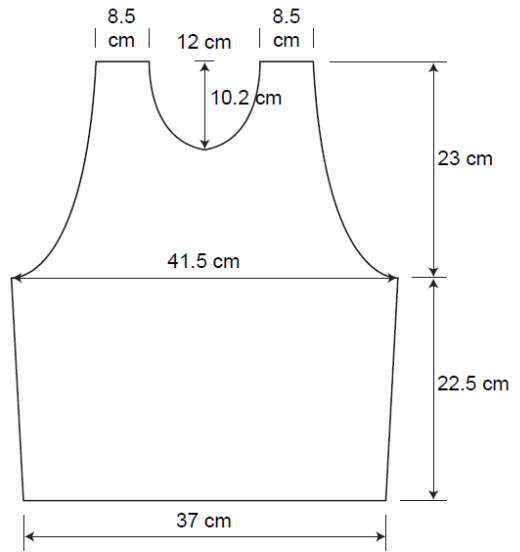

Cross-Country - Ladies

**Measurement table for ski length and weight – BMI 21.0 – MEN (valid from summer 2011)**

Body Height	A		B		C		D		E		F	
	Weight with suit and boots	Ski length	Weight with suit and boots	Ski length	Weight with suit and boots	Ski length	Weight with suit and boots	Ski length	Weight with suit and boots	Ski length	Weight with suit and boots	Ski length
BMI / %	21.000	145.0	20.875	144.5	20.750	144.0	20.625	143.5	20.500	143.0	20.375	142.5
cm	kg	cm	kg	cm	kg	cm	kg	cm	kg	cm	kg	cm
140	41.2	203	40.9	202	40.7	202	40.4	201	40.2	200	39.9	200
141	41.8	204	41.5	204	41.3	203	41.0	202	40.8	202	40.5	201
142	42.3	206	42.1	205	41.8	204	41.6	204	41.3	203	41.1	202
143	42.9	207	42.7	207	42.4	206	42.2	205	41.9	204	41.7	204
144	43.5	209	43.3	208	43.0	207	42.8	207	42.5	206	42.2	205
145	44.2	210	43.9	210	43.6	209	43.4	208	43.1	207	42.8	207
146	44.8	212	44.5	211	44.2	210	44.0	210	43.7	209	43.4	208
147	45.4	213	45.1	212	44.8	212	44.6	211	44.3	210	44.0	209
148	46.0	215	45.7	214	45.5	213	45.2	212	44.9	212	44.6	211
149	46.6	216	46.3	215	46.1	215	45.8	214	45.5	213	45.2	212
150	47.3	218	47.0	217	46.7	216	46.4	215	46.1	215	45.8	214
151	47.9	219	47.6	218	47.3	217	47.0	217	46.7	216	46.5	215
152	48.5	220	48.2	220	47.9	219	47.7	218	47.4	217	47.1	217
153	49.2	222	48.9	221	48.6	220	48.3	220	48.0	219	47.7	218
154	49.8	223	49.5	223	49.2	222	48.9	221	48.6	220	48.3	219
155	50.5	225	50.2	224	49.9	223	49.6	222	49.3	222	49.0	221
156	51.1	226	50.8	225	50.5	225	50.2	224	49.9	223	49.6	222
157	51.8	228	51.5	227	51.1	226	50.8	225	50.5	225	50.2	224
158	52.4	229	52.1	228	51.8	228	51.5	227	51.2	226	50.9	225
159	53.1	231	52.8	230	52.5	229	52.1	228	51.8	227	51.5	227
160	53.8	232	53.4	231	53.1	230	52.8	230	52.5	229	52.2	228
161	54.4	233	54.1	233	53.8	232	53.5	231	53.1	230	52.8	229
162	55.1	235	54.8	234	54.5	233	54.1	232	53.8	232	53.5	231
163	55.8	236	55.5	236	55.1	235	54.8	234	54.5	233	54.1	232
164	56.5	238	56.1	237	55.8	236	55.5	235	55.1	235	54.8	234
165	57.2	239	56.8	238	56.5	238	56.2	237	55.8	236	55.5	235
166	57.9	241	57.5	240	57.2	239	56.8	238	56.5	237	56.1	237
167	58.6	242	58.2	241	57.9	240	57.5	240	57.2	239	56.8	238
168	59.3	244	58.9	243	58.6	242	58.2	241	57.9	240	57.5	239
169	60.0	245	59.6	244	59.3	243	58.9	243	58.6	242	58.2	241
170	60.7	247	60.3	246	60.0	245	59.6	244	59.2	243	58.9	242
171	61.4	248	61.0	247	60.7	246	60.3	245	59.9	245	59.6	244
172	62.1	249	61.8	249	61.4	248	61.0	247	60.6	246	60.3	245
173	62.9	251	62.5	250	62.1	249	61.7	248	61.4	247	61.0	247
174	63.6	252	63.2	251	62.8	251	62.4	250	62.1	249	61.7	248
175	64.3	254	63.9	253	63.5	252	63.2	251	62.8	250	62.4	249
176	65.0	255	64.7	254	64.3	253	63.9	253	63.5	252	63.1	251
177	65.8	257	65.4	256	65.0	255	64.6	254	64.2	253	63.8	252
178	66.5	258	66.1	257	65.7	256	65.3	255	65.0	255	64.6	254
179	67.3	260	66.9	259	66.5	258	66.1	257	65.7	256	65.3	255
180	68.0	261	67.6	260	67.2	259	66.8	258	66.4	257	66.0	257
181	68.8	262	68.4	262	68.0	261	67.6	260	67.2	259	66.8	258
182	69.6	264	69.1	263	68.7	262	68.3	261	67.9	260	67.5	259
183	70.3	265	69.9	264	69.5	264	69.1	263	68.7	262	68.2	261
184	71.1	267	70.7	266	70.3	265	69.8	264	69.4	263	69.0	262
185	71.9	268	71.4	267	71.0	266	70.6	265	70.2	265	69.7	264
186	72.7	270	72.2	269	71.8	268	71.4	267	70.9	266	70.5	265
187	73.4	271	73.0	270	72.6	269	72.1	268	71.7	267	71.2	266
188	74.2	273	73.8	272	73.3	271	72.9	270	72.5	269	72.0	268
189	75.0	274	74.6	273	74.1	272	73.7	271	73.2	270	72.8	269
190	75.8	276	75.4	275	74.9	274	74.5	273	74.0	272	73.6	271
191	76.6	277	76.2	276	75.7	275	75.2	274	74.8	273	74.3	272
192	77.4	278	77.0	277	76.5	276	76.0	276	75.6	275	75.1	274
193	78.2	280	77.8	279	77.3	278	76.8	277	76.4	276	75.9	275
194	79.0	281	78.6	280	78.1	279	77.6	278	77.2	277	76.7	276
195	79.9	283	79.4	282	78.9	281	78.4	280	78.0	279	77.5	278
196	80.7	284	80.2	283	79.7	282	79.2	281	78.8	280	78.3	279
197	81.5	286	81.0	285	80.5	284	80.0	283	79.6	282	79.1	281
198	82.3	287	81.8	286	81.3	285	80.9	284	80.4	283	79.9	282
199	83.2	289	82.7	288	82.2	287	81.7	286	81.2	285	80.7	284
200	84.0	290	83.5	289	83.0	288	82.5	287	82.0	286	81.5	285

Body Height	G		H		I		J		K		L	
	Weight with suit and boots	Ski length	Weight with suit and boots	Ski length	Weight with suit and boots	Ski length	Weight with suit and boots	Ski length	Weight with suit and boots	Ski length	Weight with suit and boots	Ski length
BMI / %	20.250	142.0	20.125	141.5	20.000	141.0	19.875	140.5	19.750	140.0	19.625	139.5
cm	kg	cm	kg	cm	kg	cm	kg	cm	kg	cm	kg	cm
140	39.7	199	39.4	198	39.2	197	39.0	197	38.7	196	38.5	195
141	40.3	200	40.0	200	39.8	199	39.5	198	39.3	197	39.0	197
142	40.8	202	40.6	201	40.3	200	40.1	200	39.8	199	39.6	198
143	41.4	203	41.2	202	40.9	202	40.6	201	40.4	200	40.1	199
144	42.0	204	41.7	204	41.5	203	41.2	202	41.0	202	40.7	201
145	42.6	206	42.3	205	42.1	204	41.8	204	41.5	203	41.3	202
146	43.2	207	42.9	207	42.6	206	42.4	205	42.1	204	41.8	204
147	43.8	209	43.5	208	43.2	207	42.9	207	42.7	206	42.4	205
148	44.4	210	44.1	209	43.8	209	43.5	208	43.3	207	43.0	206
149	45.0	212	44.7	211	44.4	210	44.1	209	43.8	209	43.6	208
150	45.6	213	45.3	212	45.0	212	44.7	211	44.4	210	44.2	209
151	46.2	214	45.9	214	45.6	213	45.3	212	45.0	211	44.7	211
152	46.8	216	46.5	215	46.2	214	45.9	214	45.6	213	45.3	212
153	47.4	217	47.1	216	46.8	216	46.5	215	46.2	214	45.9	213
154	48.0	219	47.7	218	47.4	217	47.1	216	46.8	216	46.5	215
155	48.7	220	48.4	219	48.1	219	47.7	218	47.4	217	47.1	216
156	49.3	222	49.0	221	48.7	220	48.4	219	48.1	218	47.8	218
157	49.9	223	49.6	222	49.3	221	49.0	221	48.7	220	48.4	219
158	50.6	224	50.2	224	49.9	223	49.6	222	49.3	221	49.0	220
159	51.2	226	50.9	225	50.6	224	50.2	223	49.9	223	49.6	222
160	51.8	227	51.5	226	51.2	226	50.9	225	50.6	224	50.2	223
161	52.5	229	52.2	228	51.8	227	51.5	226	51.2	225	50.9	225
162	53.1	230	52.8	229	52.5	228	52.2	228	51.8	227	51.5	226
163	53.8	231	53.5	231	53.1	230	52.8	229	52.5	228	52.1	227
164	54.5	233	54.1	232	53.8	231	53.5	230	53.1	230	52.8	229
165	55.1	234	54.8	233	54.5	233	54.1	232	53.8	231	53.4	230
166	55.8	236	55.5	235	55.1	234	54.8	233	54.4	232	54.1	232
167	56.5	237	56.1	236	55.8	235	55.4	235	55.1	234	54.7	233
168	57.2	239	56.8	238	56.4	237	56.1	236	55.7	235	55.4	234
169	57.8	240	57.5	239	57.1	238	56.8	237	56.4	237	56.1	236
170	58.5	241	58.2	241	57.8	240	57.4	239	57.1	238	56.7	237
171	59.2	243	58.8	242	58.5	241	58.1	240	57.8	239	57.4	239
172	59.9	244	59.5	243	59.2	243	58.8	242	58.4	241	58.1	240
173	60.6	246	60.2	245	59.9	244	59.5	243	59.1	242	58.7	241
174	61.3	247	60.9	246	60.6	245	60.2	244	59.8	244	59.4	243
175	62.0	249	61.6	248	61.3	247	60.9	246	60.5	245	60.1	244
176	62.7	250	62.3	249	62.0	248	61.6	247	61.2	246	60.8	246
177	63.4	251	63.0	250	62.7	250	62.3	249	61.9	248	61.5	247
178	64.2	253	63.8	252	63.4	251	63.0	250	62.6	249	62.2	248
179	64.9	254	64.5	253	64.1	252	63.7	251	63.3	251	62.9	250
180	65.6	256	65.2	255	64.8	254	64.4	253	64.0	252	63.6	251
181	66.3	257	65.9	256	65.5	255	65.1	254	64.7	253	64.3	252
182	67.1	258	66.7	258	66.2	257	65.8	256	65.4	255	65.0	254
183	67.8	260	67.4	259	67.0	258	66.6	257	66.1	256	65.7	255
184	68.6	261	68.1	260	67.7	259	67.3	259	66.9	258	66.4	257
185	69.3	263	68.9	262	68.5	261	68.0	260	67.6	259	67.2	258
186	70.1	264	69.6	263	69.2	262	68.8	261	68.3	260	67.9	259
187	70.8	266	70.4	265	69.9	264	69.5	263	69.1	262	68.6	261
188	71.6	267	71.1	266	70.7	265	70.2	264	69.8	263	69.4	262
189	72.3	268	71.9	267	71.4	266	71.0	266	70.5	265	70.1	264
190	73.1	270	72.7	269	72.2	268	71.7	267	71.3	266	70.8	265
191	73.9	271	73.4	270	73.0	269	72.5	268	72.0	267	71.6	266
192	74.6	273	74.2	272	73.7	271	73.3	270	72.8	269	72.3	268
193	75.4	274	75.0	273	74.5	272	74.0	271	73.6	270	73.1	269
194	76.2	275	75.7	275	75.3	274	74.8	273	74.3	272	73.9	271
195	77.0	277	76.5	276	76.1	275	75.6	274	75.1	273	74.6	272
196	77.8	278	77.3	277	76.8	276	76.4	275	75.9	274	75.4	273
197	78.6	280	78.1	279	77.6	278	77.1	277	76.6	276	76.2	275
198	79.4	281	78.9	280	78.4	279	77.9	278	77.4	277	76.9	276
199	80.2	283	79.7	282	79.2	281	78.7	280	78.2	279	77.7	278
200	81.0	284	80.5	283	80.0	282	79.5	281	79.0	280	78.5	279

Body Height	M		N		O		P		Q		R	
	Weight with suit and boots	Ski length	Weight with suit and boots	Ski length	Weight with suit and boots	Ski length	Weight with suit and boots	Ski length	Weight with suit and boots	Ski length	Weight with suit and boots	Ski length
BMI / %	19.500	139.0	19.375	138.5	19.250	138.0	19.125	137.5	19.000	137.0	18.875	136.5
cm	kg	cm	kg	cm	kg	cm	kg	cm	kg	cm	kg	cm
140	38.2	195	38.0	194	37.7	193	37.5	193	37.2	192	37.0	191
141	38.8	196	38.5	195	38.3	195	38.0	194	37.8	193	37.5	192
142	39.3	197	39.1	197	38.8	196	38.6	195	38.3	195	38.1	194
143	39.9	199	39.6	198	39.4	197	39.1	197	38.9	196	38.6	195
144	40.4	200	40.2	199	39.9	199	39.7	198	39.4	197	39.1	197
145	41.0	202	40.7	201	40.5	200	40.2	199	39.9	199	39.7	198
146	41.6	203	41.3	202	41.0	201	40.8	201	40.5	200	40.2	199
147	42.1	204	41.9	204	41.6	203	41.3	202	41.1	201	40.8	201
148	42.7	206	42.4	205	42.2	204	41.9	204	41.6	203	41.3	202
149	43.3	207	43.0	206	42.7	206	42.5	205	42.2	204	41.9	203
150	43.9	209	43.6	208	43.3	207	43.0	206	42.8	206	42.5	205
151	44.5	210	44.2	209	43.9	208	43.6	208	43.3	207	43.0	206
152	45.1	211	44.8	211	44.5	210	44.2	209	43.9	208	43.6	207
153	45.6	213	45.4	212	45.1	211	44.8	210	44.5	210	44.2	209
154	46.2	214	45.9	213	45.7	213	45.4	212	45.1	211	44.8	210
155	46.8	215	46.5	215	46.2	214	45.9	213	45.6	212	45.3	212
156	47.5	217	47.2	216	46.8	215	46.5	215	46.2	214	45.9	213
157	48.1	218	47.8	217	47.4	217	47.1	216	46.8	215	46.5	214
158	48.7	220	48.4	219	48.1	218	47.7	217	47.4	216	47.1	216
159	49.3	221	49.0	220	48.7	219	48.3	219	48.0	218	47.7	217
160	49.9	222	49.6	222	49.3	221	49.0	220	48.6	219	48.3	218
161	50.5	224	50.2	223	49.9	222	49.6	221	49.2	221	48.9	220
162	51.2	225	50.8	224	50.5	224	50.2	223	49.9	222	49.5	221
163	51.8	227	51.5	226	51.1	225	50.8	224	50.5	223	50.1	222
164	52.4	228	52.1	227	51.8	226	51.4	226	51.1	225	50.8	224
165	53.1	229	52.7	229	52.4	228	52.1	227	51.7	226	51.4	225
166	53.7	231	53.4	230	53.0	229	52.7	228	52.4	227	52.0	227
167	54.4	232	54.0	231	53.7	230	53.3	230	53.0	229	52.6	228
168	55.0	234	54.7	233	54.3	232	54.0	231	53.6	230	53.3	229
169	55.7	235	55.3	234	55.0	233	54.6	232	54.3	232	53.9	231
170	56.4	236	56.0	235	55.6	235	55.3	234	54.9	233	54.5	232
171	57.0	238	56.7	237	56.3	236	55.9	235	55.6	234	55.2	233
172	57.7	239	57.3	238	56.9	237	56.6	237	56.2	236	55.8	235
173	58.4	240	58.0	240	57.6	239	57.2	238	56.9	237	56.5	236
174	59.0	242	58.7	241	58.3	240	57.9	239	57.5	238	57.1	238
175	59.7	243	59.3	242	59.0	242	58.6	241	58.2	240	57.8	239
176	60.4	245	60.0	244	59.6	243	59.2	242	58.9	241	58.5	240
177	61.1	246	60.7	245	60.3	244	59.9	243	59.5	242	59.1	242
178	61.8	247	61.4	247	61.0	246	60.6	245	60.2	244	59.8	243
179	62.5	249	62.1	248	61.7	247	61.3	246	60.9	245	60.5	244
180	63.2	250	62.8	249	62.4	248	62.0	248	61.6	247	61.2	246
181	63.9	252	63.5	251	63.1	250	62.7	249	62.2	248	61.8	247
182	64.6	253	64.2	252	63.8	251	63.3	250	62.9	249	62.5	248
183	65.3	254	64.9	253	64.5	253	64.0	252	63.6	251	63.2	250
184	66.0	256	65.6	255	65.2	254	64.7	253	64.3	252	63.9	251
185	66.7	257	66.3	256	65.9	255	65.5	254	65.0	253	64.6	253
186	67.5	259	67.0	258	66.6	257	66.2	256	65.7	255	65.3	254
187	68.2	260	67.8	259	67.3	258	66.9	257	66.4	256	66.0	255
188	68.9	261	68.5	260	68.0	259	67.6	259	67.2	258	66.7	257
189	69.7	263	69.2	262	68.8	261	68.3	260	67.9	259	67.4	258
190	70.4	264	69.9	263	69.5	262	69.0	261	68.6	260	68.1	259
191	71.1	265	70.7	265	70.2	264	69.8	263	69.3	262	68.9	261
192	71.9	267	71.4	266	71.0	265	70.5	264	70.0	263	69.6	262
193	72.6	268	72.2	267	71.7	266	71.2	265	70.8	264	70.3	263
194	73.4	270	72.9	269	72.4	268	72.0	267	71.5	266	71.0	265
195	74.1	271	73.7	270	73.2	269	72.7	268	72.2	267	71.8	266
196	74.9	272	74.4	271	74.0	270	73.5	270	73.0	269	72.5	268
197	75.7	274	75.2	273	74.7	272	74.2	271	73.7	270	73.3	269
198	76.4	275	76.0	274	75.5	273	75.0	272	74.5	271	74.0	270
199	77.2	277	76.7	276	76.2	275	75.7	274	75.2	273	74.7	272
200	78.0	278	77.5	277	77.0	276	76.5	275	76.0	274	75.5	273

Body Height	S		T		U		V		Z	
	Weight with suit and boots	Ski length	Weight with suit and boots	Ski length	Weight with suit and boots	Ski length	Weight with suit and boots	Ski length	Weight with suit and boots	Ski length
BMI / %	18.750	136.0	18.625	135.5	18.500	135.0	18.375	134.5	18.250	134.0
cm	kg	cm	kg	cm	kg	cm	kg	cm	kg	cm
140	36.8	190	36.5	190	36.3	189	36.0	188	35.8	188
141	37.3	192	37.0	191	36.8	190	36.5	190	36.3	189
142	37.8	193	37.6	192	37.3	192	37.1	191	36.8	190
143	38.3	194	38.1	194	37.8	193	37.6	192	37.3	192
144	38.9	196	38.6	195	38.4	194	38.1	194	37.8	193
145	39.4	197	39.2	196	38.9	196	38.6	195	38.4	194
146	40.0	199	39.7	198	39.4	197	39.2	196	38.9	196
147	40.5	200	40.2	199	40.0	198	39.7	198	39.4	197
148	41.1	201	40.8	201	40.5	200	40.2	199	40.0	198
149	41.6	203	41.3	202	41.1	201	40.8	200	40.5	200
150	42.2	204	41.9	203	41.6	203	41.3	202	41.1	201
151	42.8	205	42.5	205	42.2	204	41.9	203	41.6	202
152	43.3	207	43.0	206	42.7	205	42.5	204	42.2	204
153	43.9	208	43.6	207	43.3	207	43.0	206	42.7	205
154	44.5	209	44.2	209	43.9	208	43.6	207	43.3	206
155	45.0	211	44.7	210	44.4	209	44.1	208	43.8	208
156	45.6	212	45.3	211	45.0	211	44.7	210	44.4	209
157	46.2	214	45.9	213	45.6	212	45.3	211	45.0	210
158	46.8	215	46.5	214	46.2	213	45.9	213	45.6	212
159	47.4	216	47.1	215	46.8	215	46.5	214	46.1	213
160	48.0	218	47.7	217	47.4	216	47.0	215	46.7	214
161	48.6	219	48.3	218	48.0	217	47.6	217	47.3	216
162	49.2	220	48.9	220	48.6	219	48.2	218	47.9	217
163	49.8	222	49.5	221	49.2	220	48.8	219	48.5	218
164	50.4	223	50.1	222	49.8	221	49.4	221	49.1	220
165	51.0	224	50.7	224	50.4	223	50.0	222	49.7	221
166	51.7	226	51.3	225	51.0	224	50.6	223	50.3	222
167	52.3	227	51.9	226	51.6	225	51.2	225	50.9	224
168	52.9	228	52.6	228	52.2	227	51.9	226	51.5	225
169	53.6	230	53.2	229	52.8	228	52.5	227	52.1	226
170	54.2	231	53.8	230	53.5	230	53.1	229	52.7	228
171	54.8	233	54.5	232	54.1	231	53.7	230	53.4	229
172	55.5	234	55.1	233	54.7	232	54.4	231	54.0	230
173	56.1	235	55.7	234	55.4	234	55.0	233	54.6	232
174	56.8	237	56.4	236	56.0	235	55.6	234	55.3	233
175	57.4	238	57.0	237	56.7	236	56.3	235	55.9	235
176	58.1	239	57.7	238	57.3	238	56.9	237	56.5	236
177	58.7	241	58.4	240	58.0	239	57.6	238	57.2	237
178	59.4	242	59.0	241	58.6	240	58.2	239	57.8	239
179	60.1	243	59.7	243	59.3	242	58.9	241	58.5	240
180	60.8	245	60.3	244	59.9	243	59.5	242	59.1	241
181	61.4	246	61.0	245	60.6	244	60.2	243	59.8	243
182	62.1	248	61.7	247	61.3	246	60.9	245	60.5	244
183	62.8	249	62.4	248	62.0	247	61.5	246	61.1	245
184	63.5	250	63.1	249	62.6	248	62.2	247	61.8	247
185	64.2	252	63.7	251	63.3	250	62.9	249	62.5	248
186	64.9	253	64.4	252	64.0	251	63.6	250	63.1	249
187	65.6	254	65.1	253	64.7	252	64.3	252	63.8	251
188	66.3	256	65.8	255	65.4	254	64.9	253	64.5	252
189	67.0	257	66.5	256	66.1	255	65.6	254	65.2	253
190	67.7	258	67.2	257	66.8	257	66.3	256	65.9	255
191	68.4	260	67.9	259	67.5	258	67.0	257	66.6	256
192	69.1	261	68.7	260	68.2	259	67.7	258	67.3	257
193	69.8	262	69.4	262	68.9	261	68.4	260	68.0	259
194	70.6	264	70.1	263	69.6	262	69.2	261	68.7	260
195	71.3	265	70.8	264	70.3	263	69.9	262	69.4	261
196	72.0	267	71.5	266	71.1	265	70.6	264	70.1	263
197	72.8	268	72.3	267	71.8	266	71.3	265	70.8	264
198	73.5	269	73.0	268	72.5	267	72.0	266	71.5	265
199	74.3	271	73.8	270	73.3	269	72.8	268	72.3	267
200	75.0	272	74.5	271	74.0	270	73.5	269	73.0	268

**Measurement table for ski length and weight – BMI 20.5 – Ladies (valid from summer 2011)**

Body Height	A		B		C		D		E		F	
	Weight with suit and boots	Ski length	Weight with suit and boots	Ski length	Weight with suit and boots	Ski length	Weight with suit and boots	Ski length	Weight with suit and boots	Ski length	Weight with suit and boots	Ski length
BMI / %	20.500	145.0	20.375	144.5	20.250	144.0	20.125	143.5	20.000	143.0	19.875	142.5
cm	kg	cm	kg	cm	kg	cm	kg	cm	kg	cm	kg	cm
140	40.2	203	39.9	202	39.7	202	39.4	201	39.2	200	39.0	200
141	40.8	204	40.5	204	40.3	203	40.0	202	39.8	202	39.5	201
142	41.3	206	41.1	205	40.8	204	40.6	204	40.3	203	40.1	202
143	41.9	207	41.7	207	41.4	206	41.2	205	40.9	204	40.6	204
144	42.5	209	42.2	208	42.0	207	41.7	207	41.5	206	41.2	205
145	43.1	210	42.8	210	42.6	209	42.3	208	42.1	207	41.8	207
146	43.7	212	43.4	211	43.2	210	42.9	210	42.6	209	42.4	208
147	44.3	213	44.0	212	43.8	212	43.5	211	43.2	210	42.9	209
148	44.9	215	44.6	214	44.4	213	44.1	212	43.8	212	43.5	211
149	45.5	216	45.2	215	45.0	215	44.7	214	44.4	213	44.1	212
150	46.1	218	45.8	217	45.6	216	45.3	215	45.0	215	44.7	214
151	46.7	219	46.5	218	46.2	217	45.9	217	45.6	216	45.3	215
152	47.4	220	47.1	220	46.8	219	46.5	218	46.2	217	45.9	217
153	48.0	222	47.7	221	47.4	220	47.1	220	46.8	219	46.5	218
154	48.6	223	48.3	223	48.0	222	47.7	221	47.4	220	47.1	219
155	49.3	225	49.0	224	48.7	223	48.4	222	48.1	222	47.7	221
156	49.9	226	49.6	225	49.3	225	49.0	224	48.7	223	48.4	222
157	50.5	228	50.2	227	49.9	226	49.6	225	49.3	225	49.0	224
158	51.2	229	50.9	228	50.6	228	50.2	227	49.9	226	49.6	225
159	51.8	231	51.5	230	51.2	229	50.9	228	50.6	227	50.2	227
160	52.5	232	52.2	231	51.8	230	51.5	230	51.2	229	50.9	228
161	53.1	233	52.8	233	52.5	232	52.2	231	51.8	230	51.5	229
162	53.8	235	53.5	234	53.1	233	52.8	232	52.5	232	52.2	231
163	54.5	236	54.1	236	53.8	235	53.5	234	53.1	233	52.8	232
164	55.1	238	54.8	237	54.5	236	54.1	235	53.8	235	53.5	234
165	55.8	239	55.5	238	55.1	238	54.8	237	54.5	236	54.1	235
166	56.5	241	56.1	240	55.8	239	55.5	238	55.1	237	54.8	237
167	57.2	242	56.8	241	56.5	240	56.1	240	55.8	239	55.4	238
168	57.9	244	57.5	243	57.2	242	56.8	241	56.4	240	56.1	239
169	58.6	245	58.2	244	57.8	243	57.5	243	57.1	242	56.8	241
170	59.2	247	58.9	246	58.5	245	58.2	244	57.8	243	57.4	242
171	59.9	248	59.6	247	59.2	246	58.8	245	58.5	245	58.1	244
172	60.6	249	60.3	249	59.9	248	59.5	247	59.2	246	58.8	245
173	61.4	251	61.0	250	60.6	249	60.2	248	59.9	247	59.5	247
174	62.1	252	61.7	251	61.3	251	60.9	250	60.6	249	60.2	248
175	62.8	254	62.4	253	62.0	252	61.6	251	61.3	250	60.9	249
176	63.5	255	63.1	254	62.7	253	62.3	253	62.0	252	61.6	251
177	64.2	257	63.8	256	63.4	255	63.0	254	62.7	253	62.3	252
178	65.0	258	64.6	257	64.2	256	63.8	255	63.4	255	63.0	254
179	65.7	260	65.3	259	64.9	258	64.5	257	64.1	256	63.7	255
180	66.4	261	66.0	260	65.6	259	65.2	258	64.8	257	64.4	257
181	67.2	262	66.8	262	66.3	261	65.9	260	65.5	259	65.1	258
182	67.9	264	67.5	263	67.1	262	66.7	261	66.2	260	65.8	259
183	68.7	265	68.2	264	67.8	264	67.4	263	67.0	262	66.6	261
184	69.4	267	69.0	266	68.6	265	68.1	264	67.7	263	67.3	262
185	70.2	268	69.7	267	69.3	266	68.9	265	68.5	265	68.0	264
186	70.9	270	70.5	269	70.1	268	69.6	267	69.2	266	68.8	265
187	71.7	271	71.2	270	70.8	269	70.4	268	69.9	267	69.5	266
188	72.5	273	72.0	272	71.6	271	71.1	270	70.7	269	70.2	268
189	73.2	274	72.8	273	72.3	272	71.9	271	71.4	270	71.0	269
190	74.0	276	73.6	275	73.1	274	72.7	273	72.2	272	71.7	271
191	74.8	277	74.3	276	73.9	275	73.4	274	73.0	273	72.5	272
192	75.6	278	75.1	277	74.6	276	74.2	276	73.7	275	73.3	274
193	76.4	280	75.9	279	75.4	278	75.0	277	74.5	276	74.0	275
194	77.2	281	76.7	280	76.2	279	75.7	278	75.3	277	74.8	276
195	78.0	283	77.5	282	77.0	281	76.5	280	76.1	279	75.6	278
196	78.8	284	78.3	283	77.8	282	77.3	281	76.8	280	76.4	279
197	79.6	286	79.1	285	78.6	284	78.1	283	77.6	282	77.1	281
198	80.4	287	79.9	286	79.4	285	78.9	284	78.4	283	77.9	282
199	81.2	289	80.7	288	80.2	287	79.7	286	79.2	285	78.7	284
200	82.0	290	81.5	289	81.0	288	80.5	287	80.0	286	79.5	285

Body Height	G		H		I		J		K		L	
	Weight with suit and boots	Ski length	Weight with suit and boots	Ski length	Weight with suit and boots	Ski length	Weight with suit and boots	Ski length	Weight with suit and boots	Ski length	Weight with suit and boots	Ski length
BMI / %	19.750	142.0	19.625	141.5	19.500	141.0	19.375	140.5	19.250	140.0	19.125	139.5
cm	kg	cm	kg	cm	kg	cm	kg	cm	kg	cm	kg	cm
140	38.7	199	38.5	198	38.2	197	38.0	197	37.7	196	37.5	195
141	39.3	200	39.0	200	38.8	199	38.5	198	38.3	197	38.0	197
142	39.8	202	39.6	201	39.3	200	39.1	200	38.8	199	38.6	198
143	40.4	203	40.1	202	39.9	202	39.6	201	39.4	200	39.1	199
144	41.0	204	40.7	204	40.4	203	40.2	202	39.9	202	39.7	201
145	41.5	206	41.3	205	41.0	204	40.7	204	40.5	203	40.2	202
146	42.1	207	41.8	207	41.6	206	41.3	205	41.0	204	40.8	204
147	42.7	209	42.4	208	42.1	207	41.9	207	41.6	206	41.3	205
148	43.3	210	43.0	209	42.7	209	42.4	208	42.2	207	41.9	206
149	43.8	212	43.6	211	43.3	210	43.0	209	42.7	209	42.5	208
150	44.4	213	44.2	212	43.9	212	43.6	211	43.3	210	43.0	209
151	45.0	214	44.7	214	44.5	213	44.2	212	43.9	211	43.6	211
152	45.6	216	45.3	215	45.1	214	44.8	214	44.5	213	44.2	212
153	46.2	217	45.9	216	45.6	216	45.4	215	45.1	214	44.8	213
154	46.8	219	46.5	218	46.2	217	45.9	216	45.7	216	45.4	215
155	47.4	220	47.1	219	46.8	219	46.5	218	46.2	217	45.9	216
156	48.1	222	47.8	221	47.5	220	47.2	219	46.8	218	46.5	218
157	48.7	223	48.4	222	48.1	221	47.8	221	47.4	220	47.1	219
158	49.3	224	49.0	224	48.7	223	48.4	222	48.1	221	47.7	220
159	49.9	226	49.6	225	49.3	224	49.0	223	48.7	223	48.3	222
160	50.6	227	50.2	226	49.9	226	49.6	225	49.3	224	49.0	223
161	51.2	229	50.9	228	50.5	227	50.2	226	49.9	225	49.6	225
162	51.8	230	51.5	229	51.2	228	50.8	228	50.5	227	50.2	226
163	52.5	231	52.1	231	51.8	230	51.5	229	51.1	228	50.8	227
164	53.1	233	52.8	232	52.4	231	52.1	230	51.8	230	51.4	229
165	53.8	234	53.4	233	53.1	233	52.7	232	52.4	231	52.1	230
166	54.4	236	54.1	235	53.7	234	53.4	233	53.0	232	52.7	232
167	55.1	237	54.7	236	54.4	235	54.0	235	53.7	234	53.3	233
168	55.7	239	55.4	238	55.0	237	54.7	236	54.3	235	54.0	234
169	56.4	240	56.1	239	55.7	238	55.3	237	55.0	237	54.6	236
170	57.1	241	56.7	241	56.4	240	56.0	239	55.6	238	55.3	237
171	57.8	243	57.4	242	57.0	241	56.7	240	56.3	239	55.9	239
172	58.4	244	58.1	243	57.7	243	57.3	242	56.9	241	56.6	240
173	59.1	246	58.7	245	58.4	244	58.0	243	57.6	242	57.2	241
174	59.8	247	59.4	246	59.0	245	58.7	244	58.3	244	57.9	243
175	60.5	249	60.1	248	59.7	247	59.3	246	59.0	245	58.6	244
176	61.2	250	60.8	249	60.4	248	60.0	247	59.6	246	59.2	246
177	61.9	251	61.5	250	61.1	250	60.7	249	60.3	248	59.9	247
178	62.6	253	62.2	252	61.8	251	61.4	250	61.0	249	60.6	248
179	63.3	254	62.9	253	62.5	252	62.1	251	61.7	251	61.3	250
180	64.0	256	63.6	255	63.2	254	62.8	253	62.4	252	62.0	251
181	64.7	257	64.3	256	63.9	255	63.5	254	63.1	253	62.7	252
182	65.4	258	65.0	258	64.6	257	64.2	256	63.8	255	63.3	254
183	66.1	260	65.7	259	65.3	258	64.9	257	64.5	256	64.0	255
184	66.9	261	66.4	260	66.0	259	65.6	259	65.2	258	64.7	257
185	67.6	263	67.2	262	66.7	261	66.3	260	65.9	259	65.5	258
186	68.3	264	67.9	263	67.5	262	67.0	261	66.6	260	66.2	259
187	69.1	266	68.6	265	68.2	264	67.8	263	67.3	262	66.9	261
188	69.8	267	69.4	266	68.9	265	68.5	264	68.0	263	67.6	262
189	70.5	268	70.1	267	69.7	266	69.2	266	68.8	265	68.3	264
190	71.3	270	70.8	269	70.4	268	69.9	267	69.5	266	69.0	265
191	72.0	271	71.6	270	71.1	269	70.7	268	70.2	267	69.8	266
192	72.8	273	72.3	272	71.9	271	71.4	270	71.0	269	70.5	268
193	73.6	274	73.1	273	72.6	272	72.2	271	71.7	270	71.2	269
194	74.3	275	73.9	275	73.4	274	72.9	273	72.4	272	72.0	271
195	75.1	277	74.6	276	74.1	275	73.7	274	73.2	273	72.7	272
196	75.9	278	75.4	277	74.9	276	74.4	275	74.0	274	73.5	273
197	76.6	280	76.2	279	75.7	278	75.2	277	74.7	276	74.2	275
198	77.4	281	76.9	280	76.4	279	76.0	278	75.5	277	75.0	276
199	78.2	283	77.7	282	77.2	281	76.7	280	76.2	279	75.7	278
200	79.0	284	78.5	283	78.0	282	77.5	281	77.0	280	76.5	279

Body Height	M		N		O		P		Q		R	
	Weight with suit and boots	Ski length	Weight with suit and boots	Ski length	Weight with suit and boots	Ski length	Weight with suit and boots	Ski length	Weight with suit and boots	Ski length	Weight with suit and boots	Ski length
BMI / %	19.000	139.0	18.875	138.5	18.750	138.0	18.625	137.5	18.500	137.0	18.375	136.5
cm	kg	cm	kg	cm	kg	cm	kg	cm	kg	cm	kg	cm
140	37.2	195	37.0	194	36.8	193	36.5	193	36.3	192	36.0	191
141	37.8	196	37.5	195	37.3	195	37.0	194	36.8	193	36.5	192
142	38.3	197	38.1	197	37.8	196	37.6	195	37.3	195	37.1	194
143	38.9	199	38.6	198	38.3	197	38.1	197	37.8	196	37.6	195
144	39.4	200	39.1	199	38.9	199	38.6	198	38.4	197	38.1	197
145	39.9	202	39.7	201	39.4	200	39.2	199	38.9	199	38.6	198
146	40.5	203	40.2	202	40.0	201	39.7	201	39.4	200	39.2	199
147	41.1	204	40.8	204	40.5	203	40.2	202	40.0	201	39.7	201
148	41.6	206	41.3	205	41.1	204	40.8	204	40.5	203	40.2	202
149	42.2	207	41.9	206	41.6	206	41.3	205	41.1	204	40.8	203
150	42.8	209	42.5	208	42.2	207	41.9	206	41.6	206	41.3	205
151	43.3	210	43.0	209	42.8	208	42.5	208	42.2	207	41.9	206
152	43.9	211	43.6	211	43.3	210	43.0	209	42.7	208	42.5	207
153	44.5	213	44.2	212	43.9	211	43.6	210	43.3	210	43.0	209
154	45.1	214	44.8	213	44.5	213	44.2	212	43.9	211	43.6	210
155	45.6	215	45.3	215	45.0	214	44.7	213	44.4	212	44.1	212
156	46.2	217	45.9	216	45.6	215	45.3	215	45.0	214	44.7	213
157	46.8	218	46.5	217	46.2	217	45.9	216	45.6	215	45.3	214
158	47.4	220	47.1	219	46.8	218	46.5	217	46.2	216	45.9	216
159	48.0	221	47.7	220	47.4	219	47.1	219	46.8	218	46.5	217
160	48.6	222	48.3	222	48.0	221	47.7	220	47.4	219	47.0	218
161	49.2	224	48.9	223	48.6	222	48.3	221	48.0	221	47.6	220
162	49.9	225	49.5	224	49.2	224	48.9	223	48.6	222	48.2	221
163	50.5	227	50.1	226	49.8	225	49.5	224	49.2	223	48.8	222
164	51.1	228	50.8	227	50.4	226	50.1	226	49.8	225	49.4	224
165	51.7	229	51.4	229	51.0	228	50.7	227	50.4	226	50.0	225
166	52.4	231	52.0	230	51.7	229	51.3	228	51.0	227	50.6	227
167	53.0	232	52.6	231	52.3	230	51.9	230	51.6	229	51.2	228
168	53.6	234	53.3	233	52.9	232	52.6	231	52.2	230	51.9	229
169	54.3	235	53.9	234	53.6	233	53.2	232	52.8	232	52.5	231
170	54.9	236	54.5	235	54.2	235	53.8	234	53.5	233	53.1	232
171	55.6	238	55.2	237	54.8	236	54.5	235	54.1	234	53.7	233
172	56.2	239	55.8	238	55.5	237	55.1	237	54.7	236	54.4	235
173	56.9	240	56.5	240	56.1	239	55.7	238	55.4	237	55.0	236
174	57.5	242	57.1	241	56.8	240	56.4	239	56.0	238	55.6	238
175	58.2	243	57.8	242	57.4	242	57.0	241	56.7	240	56.3	239
176	58.9	245	58.5	244	58.1	243	57.7	242	57.3	241	56.9	240
177	59.5	246	59.1	245	58.7	244	58.4	243	58.0	242	57.6	242
178	60.2	247	59.8	247	59.4	246	59.0	245	58.6	244	58.2	243
179	60.9	249	60.5	248	60.1	247	59.7	246	59.3	245	58.9	244
180	61.6	250	61.2	249	60.8	248	60.3	248	59.9	247	59.5	246
181	62.2	252	61.8	251	61.4	250	61.0	249	60.6	248	60.2	247
182	62.9	253	62.5	252	62.1	251	61.7	250	61.3	249	60.9	248
183	63.6	254	63.2	253	62.8	253	62.4	252	62.0	251	61.5	250
184	64.3	256	63.9	255	63.5	254	63.1	253	62.6	252	62.2	251
185	65.0	257	64.6	256	64.2	255	63.7	254	63.3	253	62.9	253
186	65.7	259	65.3	258	64.9	257	64.4	256	64.0	255	63.6	254
187	66.4	260	66.0	259	65.6	258	65.1	257	64.7	256	64.3	255
188	67.2	261	66.7	260	66.3	259	65.8	259	65.4	258	64.9	257
189	67.9	263	67.4	262	67.0	261	66.5	260	66.1	259	65.6	258
190	68.6	264	68.1	263	67.7	262	67.2	261	66.8	260	66.3	259
191	69.3	265	68.9	265	68.4	264	67.9	263	67.5	262	67.0	261
192	70.0	267	69.6	266	69.1	265	68.7	264	68.2	263	67.7	262
193	70.8	268	70.3	267	69.8	266	69.4	265	68.9	264	68.4	263
194	71.5	270	71.0	269	70.6	268	70.1	267	69.6	266	69.2	265
195	72.2	271	71.8	270	71.3	269	70.8	268	70.3	267	69.9	266
196	73.0	272	72.5	271	72.0	270	71.5	270	71.1	269	70.6	268
197	73.7	274	73.3	273	72.8	272	72.3	271	71.8	270	71.3	269
198	74.5	275	74.0	274	73.5	273	73.0	272	72.5	271	72.0	270
199	75.2	277	74.7	276	74.3	275	73.8	274	73.3	273	72.8	272
200	76.0	278	75.5	277	75.0	276	74.5	275	74.0	274	73.5	273

Body Height	S		T		U		V		Z	
	Weight with suit and boots	Ski length	Weight with suit and boots	Ski length	Weight with suit and boots	Ski length	Weight with suit and boots	Ski length	Weight with suit and boots	Ski length
BMI / %	18.250	136.0	18.125	135.5	18.000	135.0	17.875	134.5	17.750	134.0
cm	kg	cm	kg	cm	kg	cm	kg	cm	kg	cm
140	35.8	190	35.5	190	35.3	189	35.0	188	34.8	188
141	36.3	192	36.0	191	35.8	190	35.5	190	35.3	189
142	36.8	193	36.5	192	36.3	192	36.0	191	35.8	190
143	37.3	194	37.1	194	36.8	193	36.6	192	36.3	192
144	37.8	196	37.6	195	37.3	194	37.1	194	36.8	193
145	38.4	197	38.1	196	37.8	196	37.6	195	37.3	194
146	38.9	199	38.6	198	38.4	197	38.1	196	37.8	196
147	39.4	200	39.2	199	38.9	198	38.6	198	38.4	197
148	40.0	201	39.7	201	39.4	200	39.2	199	38.9	198
149	40.5	203	40.2	202	40.0	201	39.7	200	39.4	200
150	41.1	204	40.8	203	40.5	203	40.2	202	39.9	201
151	41.6	205	41.3	205	41.0	204	40.8	203	40.5	202
152	42.2	207	41.9	206	41.6	205	41.3	204	41.0	204
153	42.7	208	42.4	207	42.1	207	41.8	206	41.6	205
154	43.3	209	43.0	209	42.7	208	42.4	207	42.1	206
155	43.8	211	43.5	210	43.2	209	42.9	208	42.6	208
156	44.4	212	44.1	211	43.8	211	43.5	210	43.2	209
157	45.0	214	44.7	213	44.4	212	44.1	211	43.8	210
158	45.6	215	45.2	214	44.9	213	44.6	213	44.3	212
159	46.1	216	45.8	215	45.5	215	45.2	214	44.9	213
160	46.7	218	46.4	217	46.1	216	45.8	215	45.4	214
161	47.3	219	47.0	218	46.7	217	46.3	217	46.0	216
162	47.9	220	47.6	220	47.2	219	46.9	218	46.6	217
163	48.5	222	48.2	221	47.8	220	47.5	219	47.2	218
164	49.1	223	48.7	222	48.4	221	48.1	221	47.7	220
165	49.7	224	49.3	224	49.0	223	48.7	222	48.3	221
166	50.3	226	49.9	225	49.6	224	49.3	223	48.9	222
167	50.9	227	50.5	226	50.2	225	49.9	225	49.5	224
168	51.5	228	51.2	228	50.8	227	50.5	226	50.1	225
169	52.1	230	51.8	229	51.4	228	51.1	227	50.7	226
170	52.7	231	52.4	230	52.0	230	51.7	229	51.3	228
171	53.4	233	53.0	232	52.6	231	52.3	230	51.9	229
172	54.0	234	53.6	233	53.3	232	52.9	231	52.5	230
173	54.6	235	54.2	234	53.9	234	53.5	233	53.1	232
174	55.3	237	54.9	236	54.5	235	54.1	234	53.7	233
175	55.9	238	55.5	237	55.1	236	54.7	235	54.4	235
176	56.5	239	56.1	238	55.8	238	55.4	237	55.0	236
177	57.2	241	56.8	240	56.4	239	56.0	238	55.6	237
178	57.8	242	57.4	241	57.0	240	56.6	239	56.2	239
179	58.5	243	58.1	243	57.7	242	57.3	241	56.9	240
180	59.1	245	58.7	244	58.3	243	57.9	242	57.5	241
181	59.8	246	59.4	245	59.0	244	58.6	243	58.2	243
182	60.5	248	60.0	247	59.6	246	59.2	245	58.8	244
183	61.1	249	60.7	248	60.3	247	59.9	246	59.4	245
184	61.8	250	61.4	249	60.9	248	60.5	247	60.1	247
185	62.5	252	62.0	251	61.6	250	61.2	249	60.7	248
186	63.1	253	62.7	252	62.3	251	61.8	250	61.4	249
187	63.8	254	63.4	253	62.9	252	62.5	252	62.1	251
188	64.5	256	64.1	255	63.6	254	63.2	253	62.7	252
189	65.2	257	64.7	256	64.3	255	63.9	254	63.4	253
190	65.9	258	65.4	257	65.0	257	64.5	256	64.1	255
191	66.6	260	66.1	259	65.7	258	65.2	257	64.8	256
192	67.3	261	66.8	260	66.4	259	65.9	258	65.4	257
193	68.0	262	67.5	262	67.0	261	66.6	260	66.1	259
194	68.7	264	68.2	263	67.7	262	67.3	261	66.8	260
195	69.4	265	68.9	264	68.4	263	68.0	262	67.5	261
196	70.1	267	69.6	266	69.1	265	68.7	264	68.2	263
197	70.8	268	70.3	267	69.9	266	69.4	265	68.9	264
198	71.5	269	71.1	268	70.6	267	70.1	266	69.6	265
199	72.3	271	71.8	270	71.3	269	70.8	268	70.3	267
200	73.0	272	72.5	271	72.0	270	71.5	269	71.0	268

## Measurement table for mounting of Ski Jumping Bindings

Masstabelle für Montage der Skisprungbindung						Masstabelle für Montage der Skisprungbindung					
Measuring table for mounting of jumping bindings						Measuring table for mounting of jumping bindings					
ab Saison 2010/2011 - as from Season 2010/2011						ab Saison 2010/2011 - as from Season 2010/2011					
Body Height Körpergröße	Ski length 145% Skilänge 145%	Front ski = 57% Vorderski = 57%		Body Height Körpergröße	Ski length 145% Skilänge 145%	Front ski = 57% Vorderski = 57%		Body Height Körpergröße	Ski length 145% Skilänge 145%	Front ski = 57% Vorderski = 57%	
cm	cm	cm		cm	cm	cm		cm	cm	cm	
140	203	116		155	225	128		185	268	153	
141	204	116		156	226	129			269	153	
	205	117			227	129		186	270	154	
142	206	117		157	228	130		187	271	154	
143	207	118		158	229	131			272	155	
	208	119			230	131		188	273	156	
144	209	119		159	231	132		189	274	156	
145	210	120		160	232	132			275	157	
	211	120		161	233	133		190	276	157	
146	212	121			234	133		191	277	158	
147	213	121		162	235	134		192	278	158	
	214	122		163	236	135			279	159	
148	215	123			237	135		193	280	160	
149	216	123		164	238	136		194	281	160	
	217	124		165	239	136			282	161	
150	218	124			240	137		195	283	161	
151	219	125		166	241	137		196	284	162	
152	220	125		167	242	138			285	162	
	221	126			243	139		197	286	163	
153	222	127		168	244	139		198	287	164	
154	223	127		169	245	140			288	164	
	224	128						199	289	165	
								200	290	165	

<b>Jugend Cup - Masstabelle für Skilänge und Bindungsmontage</b>						
<b>Youth Cup - Measuring table for Ski length and mounting of the bindings</b>						
ab Saison 2010/2011 - as from Season 2010/2011						
<b>Body Height Körpergröße</b>	<b>Ski length = 140% Skilänge = 140%</b>	<b>Front ski = 57% Vorderski = 57%</b>		<b>Body Height Körpergröße</b>	<b>Ski length = 140% Skilänge = 140%</b>	<b>Front ski = 57% Vorderski = 57%</b>
<b>cm</b>	<b>cm</b>	<b>cm</b>		<b>cm</b>	<b>cm</b>	<b>cm</b>
125	175	100		156	218	124
126	176	100			219	125
	177	101		157	220	125
127	178	101		158	221	126
128	179	102			222	127
	180	103		159	223	127
129	181	103		160	224	128
130	182	104		161	225	128
131	183	104			226	129
	184	105		162	227	129
132	185	105		163	228	130
133	186	106			229	131
	187	107		164	230	131
134	188	107		165	231	132
135	189	108		166	232	132
136	190	108			233	133
	191	109		167	234	133
137	192	109		168	235	134
138	193	110			236	135
	194	111		169	237	135
139	195	111		170	238	136
140	196	112		171	239	136
141	197	112			240	137
	198	113		172	241	137
142	199	113		173	242	138
143	200	114			243	139
	201	115		174	244	139
144	202	115		175	245	140
145	203	116		176	246	140
146	204	116			247	141
	205	117		177	248	141
147	206	117		178	249	142
148	207	118			250	143
	208	119		179	251	143
149	209	119		180	252	144
150	210	120		181	253	144
151	211	120			254	145
	212	121		182	255	145
152	213	121		183	256	146
153	214	122			257	146
	215	123		184	258	147
154	216	123		185	259	148
155	217	124		186	260	148

**Article 1.2.1.2: Precision of the Profile Width**

L	Ski length
a	max. width at front portion = 115 mm
b	max. width at 57% of front portion (f) = 105 mm
c	max. width at tail portion = 115 mm
d	max. length between tip and begin of sidecut = 300 mm
e	max. length between tail and begin of sidecut = 150 mm
f	control point of b

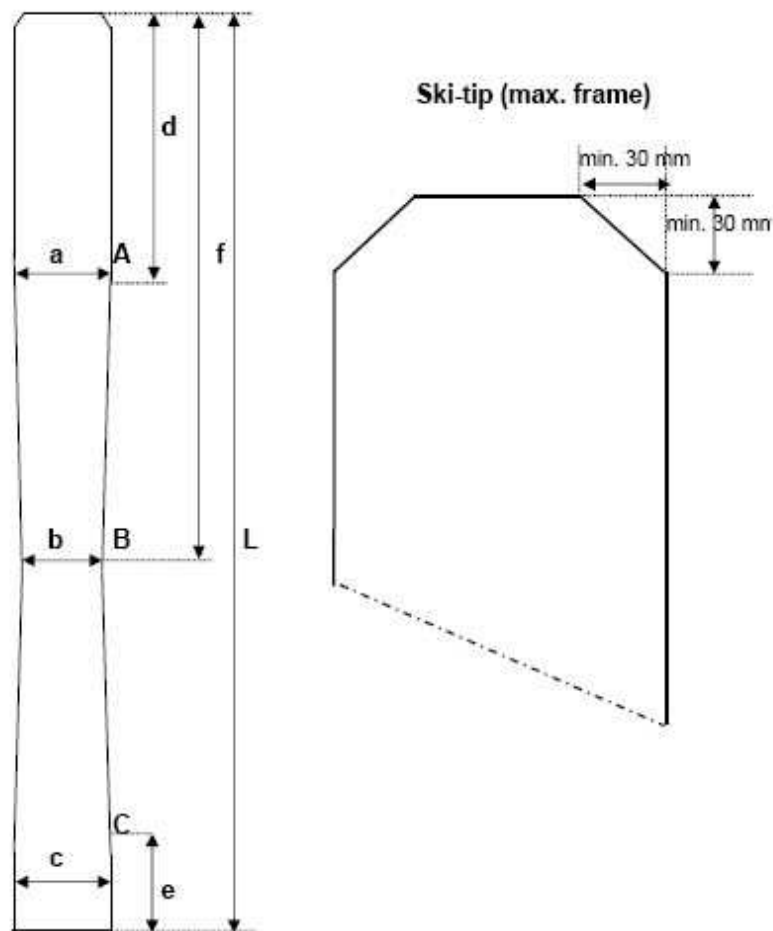

### Ski Jumping Suits

Standardized measuring control points and number of parts of material of which the suits consist

JUMPING SUITE MEN

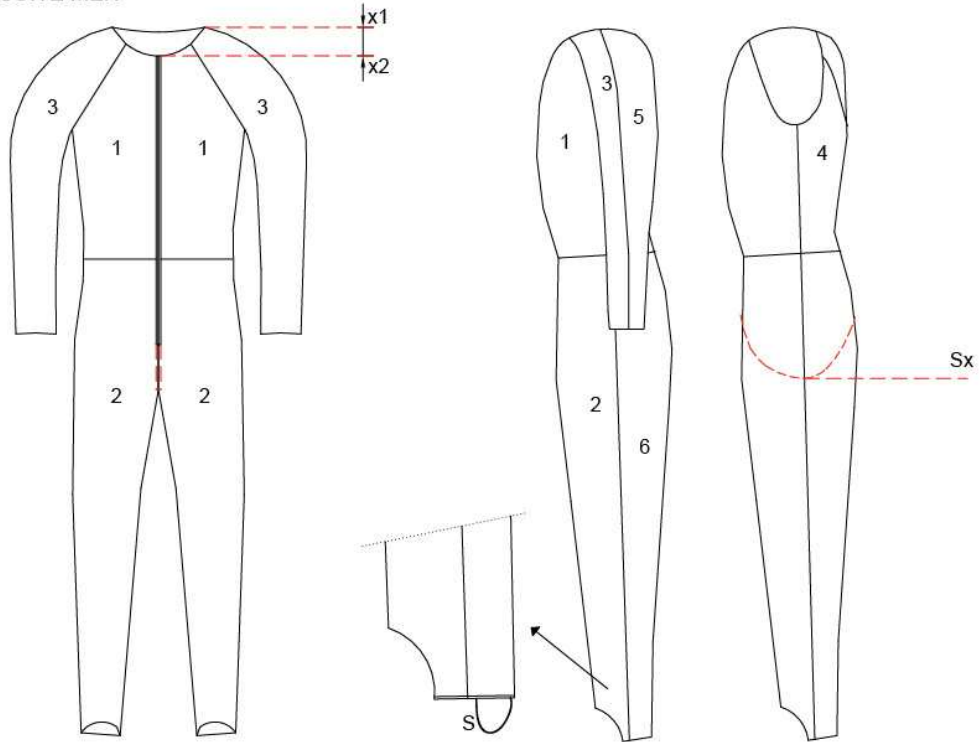

JUMPING SUITE MEN

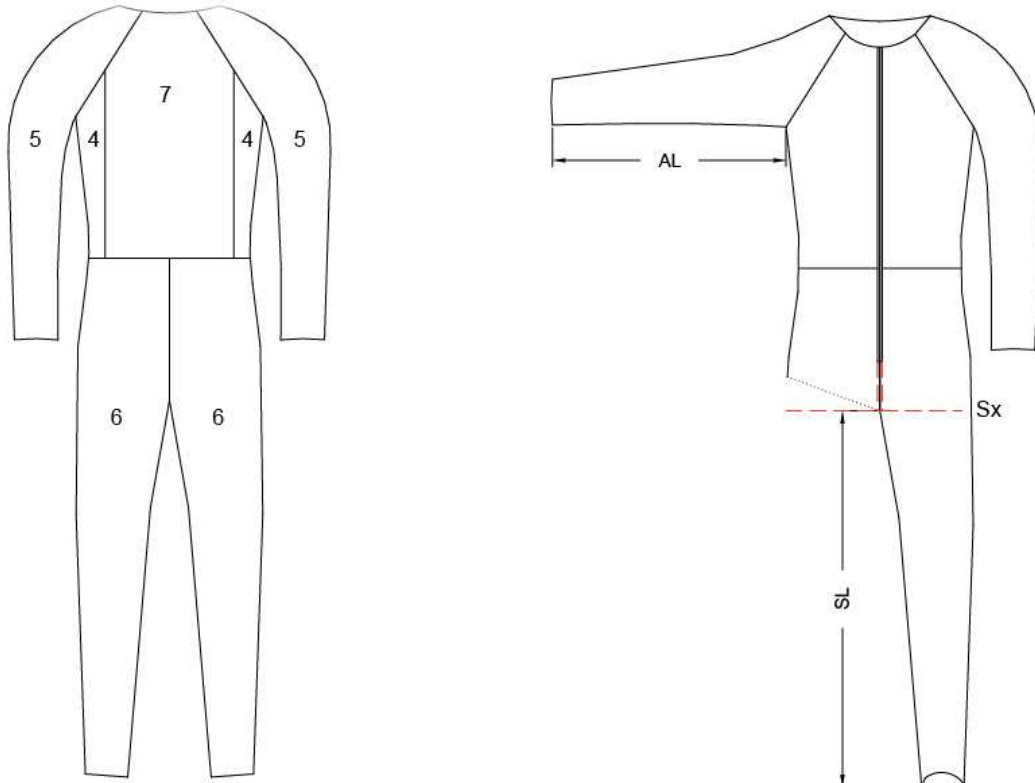

**JUMPING SUITE MEN**

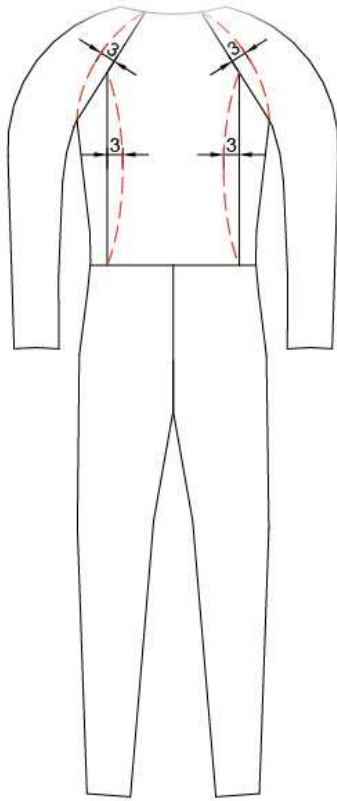

3 = 3cm

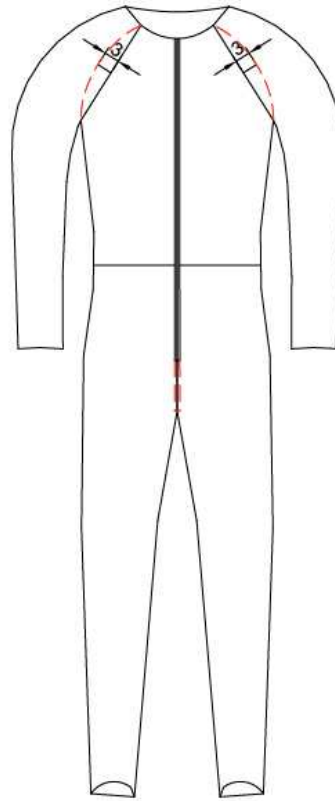

JUMPING SUITE LADIES

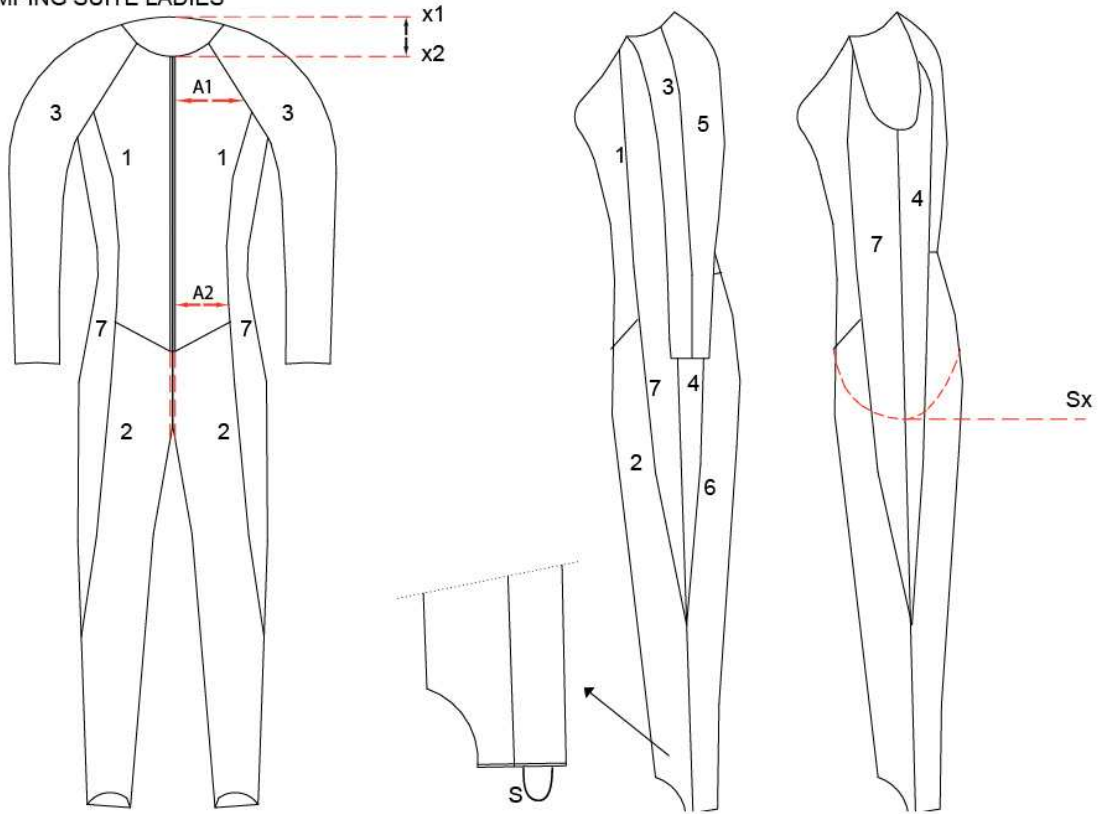

JUMPING SUITE LADIES

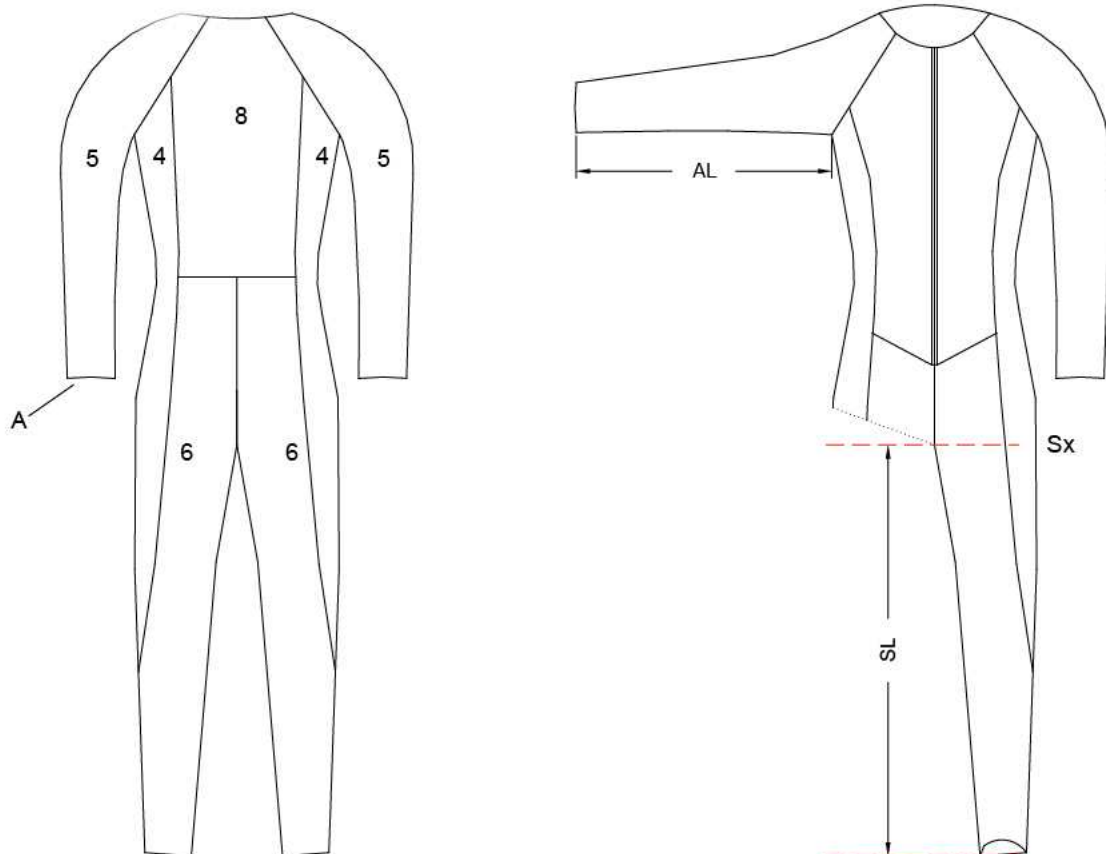

JUMPING SUITE LADIES

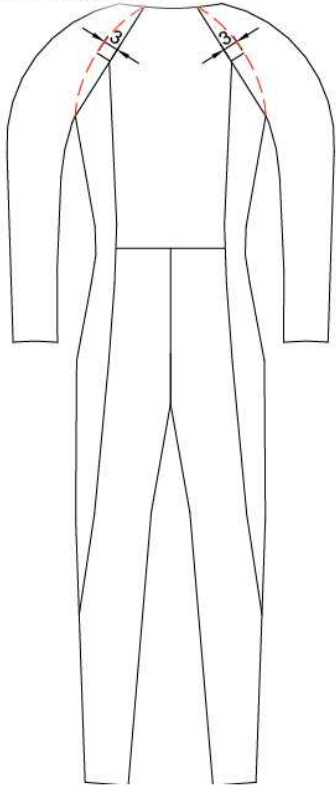

3=3cm

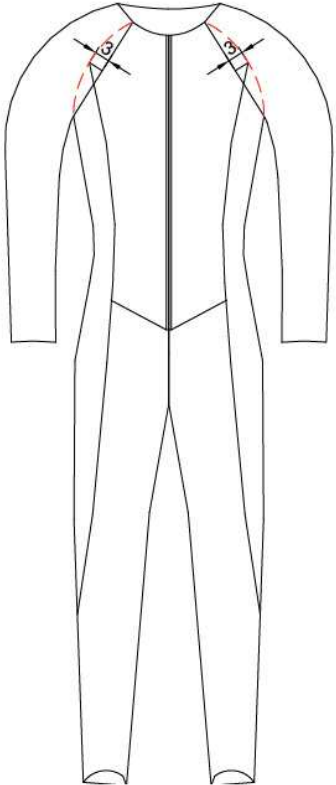

## Commercial Markings on Equipment

### 1. General Principles

Athletes may display on their clothing or equipment a commercial marking (wording or logo) specifically permitted by the rule articles 2.1 to 2.6 per product.

All other forms of commercial markings or advertising are not permitted if they are not explicitly mentioned.

Specifications concerning the size, the form and the number of commercial markings must be decided by the FIS Council.

FIS recognises as a manufacturer of ski equipment only those enterprises which effectively produce the ski equipment concerned.

No brand or model names which appear on hardware products (skis, poles, bindings, boots, helmet, etc.) can be shown on bibs or on clothing unless the name represents that of an actual producer of the clothing in question.

### 2. Actual specifications

#### 2.1 *Skis, boots, bindings, ski poles, arm and leg protection, etc.*

2.1.1 Skis, ski boots, bindings, ski poles, separate arm and leg protection and other hardware in their commercially available designs are permitted and may only carry the recognised commercial markings of the actual producers.

2.1.2 The size of the commercial markings on the arm and leg protection is limited to one marking of 12 cm<sup>2</sup> on each item of equipment.

Other sponsor markings on arm and leg protection are permitted, if those protections are part of the clothing and within the specifications of art. 2.4 (3 - 4 parts).

There is an exception for jumping skis: Please see art. 2.6.3.

A commercial marking of the actual producer on the hand protector of ski poles is permitted. The marking may be divided into two parts per individual hand protector. The total surface area of the commercial markings per hand protector is limited to 15 cm<sup>2</sup>.

#### 2.1.3 Ski straps

Only hardware (skis, ski boots, bindings, ski poles) and wax suppliers are permitted to have advertising on ski straps.

No commercial advertising is permitted. Maximum 2 ski straps per pair of skis, for example one hardware and one wax supplier.

#### 2.2 *Gloves*

A commercial marking of the actual producer of the glove is permitted. The marking may be divided into two parts per individual glove. The total surface area of the commercial markings per glove is limited to 15 cm<sup>2</sup>.

#### 2.3 *Goggles*

Goggle-straps may carry two commercial markings of the actual producer, no larger than 15 cm<sup>2</sup> each in an unstretched position.

Straps shall not measure more than 4 cm in width. In case of double straps only one strap may carry the commercial markings. Lenses must be free of advertising.

Straps (without goggles) with commercial markings of goggle suppliers may not be worn.

## 2.4 *Clothing*

2.4.1 Articles of clothing may carry commercial markings belonging to the manufacturer and/or to other sponsors (as defined in art. 2.6)

2.4.2 The total surface area of all commercial markings on the clothing of one person shall not exceed 400 cm<sup>2</sup>.

The maximum surface area for a single marking is 100 cm<sup>2</sup>.

Commercial markings of the same sponsor may not appear one above the other or one beside the other.

The National Association may decide on the placing of commercial markings.

2.4.3 Roll necks may in addition to the 400 cm<sup>2</sup> also display the manufacturer's trademark and/or sponsor, which may also be divided into two parts, with a maximum total surface area of 20cm<sup>2</sup>.

2.4.4 A military symbol (emblem), indicating the national military organisation and similar organisations may be displayed on warm-up suits (not on headgear or race suits), with a maximum size of 20 cm<sup>2</sup>. This symbol is including within the 400 cm<sup>2</sup> total surface area of the commercial markings. This applies also to markings of charitable organisations.

## 2.5 *Helmets and Headgear*

2.5.1 Helmets and headwear may carry two commercial markings of the manufacturer with a maximum size of 15 cm<sup>2</sup>, one on each side, placed over the ears. The front of helmets and headwear may only be used for the emblems of national teams, and sponsors, subject to art. 2.5.2.

2.5.2 The front (middle) of helmets and all headwear worn in competition and within the competition area, to include flower and prize-giving ceremonies, interviews etc., must carry the identification of the national ski association with a minimum size of 6 cm<sup>2</sup>.

A National Association may sign sponsorship contracts for helmet/headwear advertising rights of up to a maximum of 50 cm<sup>2</sup> (which may be divided between 2 identical - same size - logos) with firms who are not suppliers of ski equipment (hardware or software), subject to the regulations of each National Association. In such a case, the front of helmets and headwear must carry the identification of the national ski association with a minimum size of 6 cm<sup>2</sup>.

The relevant advertising must be placed either to the side of or above the identification of the national ski association. The free space between the national ski association's identification (middle front of headgear) and the sponsor's advertising (50 cm<sup>2</sup>) must be at least 1 cm.

For headbands the relevant advertising may be placed at the front of the headband, with the identification of the national ski association to the side.

No advertising is allowed on the movable or integrated chin straps of helmets.

Additionally it is not permitted to depict a website address which refers directly to the athlete, on headgear or other clothing.

## 2.6 *Other sponsors*

2.6.1 A National Association may sign sponsorship contracts with firms which are not suppliers of ski equipment (hardware and software) See also ICR art. 206.

2.6.2 The dimensions of commercial markings of such sponsors must conform to the specifications in art. 2.1., art. 2.4. or art. 2.5.

2.6.3 Jumping skis: The dimensions of commercial markings of such a sponsor on jumping skis are limited to a total surface area of 160 cm<sup>2</sup> per ski. Only one commercial marking per ski is permitted, and the marking must be identical on both skis.

2.6.4 Aerial skis: The dimensions of commercial markings of such a sponsor on aerial skis are limited to a total surface of 120 cm<sup>2</sup> per ski. Only one commercial marking per ski is permitted and the marking must be identical on both skis.

2.6.5 Snowboards: the base bottom of snowboards may only carry the recognized commercial markings of the effective producer. The top of snowboards may carry the commercial markings of the effective producer and up to five (5) other sponsors within a total size of 250 cm<sup>2</sup>, according to the regulations of the relevant National Association.

## 2.7 *Accessories*

### 2.7.1 Fanny packs

The commercial markings belong to the NSA.

The size of commercial markings is limited to a maximum of 50 cm<sup>2</sup>. The space can be used by the actual producer of the product or a commercial sponsor of the National Ski Association.

Waist bags with commercial markings may not be worn on the podium during the winners' presentation and/or the award ceremony.

### 2.7.2 Mobile phones with large neckband / use of drinking bottles

To avoid obstructing the view of the bib sponsor during the winners' presentation and/or award ceremony, large neckbands with mobile phones and drinking bottles are prohibited on the podium.

2.8 All specifications also apply for officials, coaches, technicians, support personnel and forerunners.

## **II. By-laws for commercial markings and for advertising**

### **A. Commercial markings**

- A.1 Trade names, brand names and logos of other products cannot be used as model names or be shown on ski equipment, except jumping skis and freestyle aerial skis.
- A.2 Clothing or helmets shall not represent or simulate the logo or product of a manufacturer or sponsor.
- A.3 *Measuring*
- A.3.1 The size of the commercial marking is the surface area within the actual outline of the marking. The measuring is done in an un-stretched state.
- A.3.2 If the marking is contained within an area of different colour, the total surface area of the different colour is to be measured.
- A.3.3 The accuracy of measurement of all markings is the responsibility of the respective National Association.
- A.3.4 For approval of commercial markings, it is strongly recommended to send a copy of all commercial markings in their original size, form and colour to the FIS before use. This should be done before October 1st or before the corresponding season begins in the Southern Hemisphere.

### **B. Advertising with athletes**

- B.1 Advertising with athletes is allowed subject to the permission of the National Association.
- B.2 Names, titles and illustrations of particular athletes can only be used in advertising with the permission of the National Association.
- B.3 *Not allowed in advertising with athletes:*
- B.3.1 Any kind of advertising with alcohol, tobacco, and drugs.
- B.3.2 The use of names, illustrations and titles of skiers for product names or product designs.
- B.3.3 Any direct statement or active product presentation.
- B.3.4 Any religious or racial discrimination

### **C. The above rules also apply in connection with press information or PR activities.**